

Designing the automatic train alarm system at the railway intersection

Viet Nguyen Hoang, Trang Le Thi Huyen, Hien Phan Thanh

Abstract— There are around 15,000 people killed every year in rail accidents [1]. Although railway accidents often have little in the number of cases, they have serious consequences. In countries using rail transport network as much as India, every year thousands of people die due to railway accidents (according to [2] in 2014 with 2,547 people) and will continue to increase in the recent years. Some other countries, such as Vietnam, Pakistan, Spain, USA, UK, and France... railway traffic accidents are tending to increase. Major reasons leading to railway accidents may be mentioned as: Malfunction train or light signals, Failing mechanics, Inadequate maintenance of tracks, not printing plate Safety gates, Crossings that are unprotected, negligence by the conductor, Train or parts that are defective [3]. In addition to the uncontrollable (random) causes, the initiative that is increased about the alerts at the railway intersections will contribute to reduce accidents.

This paper presents a study result of the alarm system at intersections between railway and road. The results have shown that the system has a number of advantages over existing systems that are being applied.

Index Terms— Train alarm, force pick-up

I. INTRODUCTION

At present, there are many suppliers of train alarm systems at intersections with roads such as India, Italy, China ... [4], [5]. However, these systems are only installed at some important intersections and high traffic density because of the high price. Other intersections that are not installed with an alarm system will have an imminent risk of accidents. In addition, due to the specificity of the manufacturers, the replacement, maintenance or repair of these systems is also difficult.

The train alarm system at the intersections has the signaling function (by bells, lamps, barriers ...) for vehicles when the train is coming. Announced time can be customized, normally 60s. Due to the safety of human life, the system requires reliable operation, so the signaling to transmit in the system is used by cable (standard) buried underground - underground cable. The system diagram is shown in Fig. 1, in which the S1, S4 sensors have the function detecting the coming train, and then the signals are turned on. S2, S3 sensors signal the train that passed the intersection to stop the alarm system. The current systems have to overcome some problems: due to the specific location of the railway near the

residential areas leading to the signal may be false (creating false signals); broken sensors are only identified when the train passes without alarms, it raises the potential for accidents. On the other hand, the repair is also difficult because sensor failure location can't be identified.

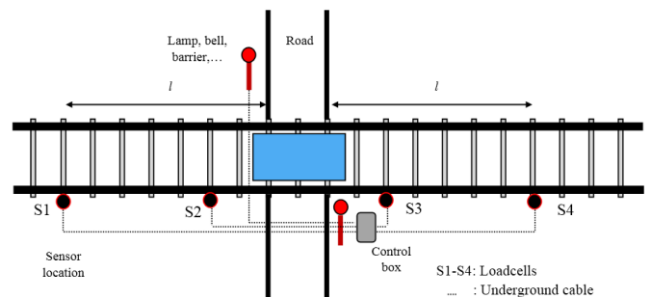

Fig. 1 The train alarm systems at the railway intersection

The team has researched and designed the system to meet the requirements of the train alarm system and added features to improve reliability, shorten troubleshooting time.

II. DESIGNING AUTOMATIC TRAIN ALARM SYSTEMS AT THE RAILWAYS INTERSECTION

The system can be divided into three parts: the sensor system, the control panel and the signaling system. In particular, the signaling system including barriers, lights, whistles... is the available equipment so the authors only design sensor systems and control box.

A. Sensor systems

This is an important part of the system. The sensor system recognizes when the train is going to arrive at an intersection, when it passes an intersection and sends signal to the controller to control signaling devices. To ensure high reliability, the signals of sensors are transmitted by cables to the control panel. There are many types of sensors that can be used, but the manufacturers are using the seismic sensor, vibration sensor and magnetic sensor to ensure the reliability.

Seismic Sensors: The principle of seismic sensors is to sense the vibration from the ground converted then into electrical signals. Typically, seismic sensors are buried underground. With a customizable sensitivity threshold, the seismic sensor will detect the train. Due to the load characteristics, the seismic vibration of the train causes the seismic difference, so they have high trust. The basic disadvantage of this sensor is that it is difficult to determine the failure state and difficult installation.

Vibration sensor: The sensor is based on the vibration when the train moves to detect it. The vibration signal is converted into an electrical signal sent to the controller.

Viet Nguyen Hoang, Faculty of Electronic Engineering, Thai Nguyen University of Technology, Thai Nguyen, Viet Nam, +84984264369.

Trang Le Thi Huyen, Faculty of Electronic Engineering, Thai Nguyen University of Technology, Thai Nguyen, Viet Nam, +84968594888.

Hien Phan Thanh, Faculty of Electronic Engineering, Thai Nguyen University of Technology, Thai Nguyen, Viet Nam, +84915064535.

In some case the surroundings create outside creates the vibration, such as: road vehicles, construction works, earthquakes, etc., the system using the sensor can generate false alarms (fake alarms).



Fig. 2 Magnetic sensor mounted on the rails [6]

The basic advantage of magnetic sensors is simple installation, but it is difficult to ensure safety. On the other hand, with the railroad near the living quarter, false alarms can occur if there is a magnetic near the sensor.

In addition to the above mentioned sensors, some other simple sensors are also tested such as proximity sensors, optical sensors, etc. However, these sensors operate with no high reliability and ineffectiveness with outdoor working conditions, so they should not be used. Another solution to improve the reliability of the sensor system is the combination of many types of sensors, however, this method has big expense.

The authors propose the use of load cell sensors in this system. The sensor is mounted between the rails and sleepers as shown in Figure 3.

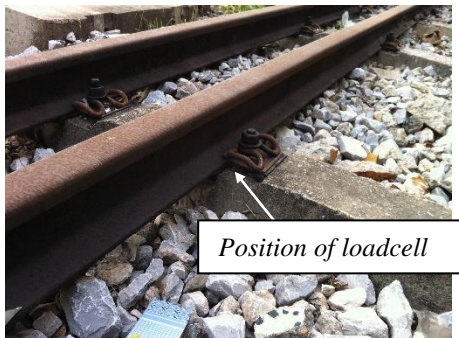

Fig. 3 Sensor installation location

The load cell sensor is selected in stainless steel (IP67), the type of sensors - measured by mass depending on the largest mass wagon train going on rails, as follows (1):

$$L_{loadcell} = W_{wagon} / x \quad (1)$$

where $L_{loadcell}$ is type of massive resistance sensors, W_{wagon} is the largest mass wagon train, x is the number of wheels of the wagon. The position of the sensors is shown in Figure 1, where l is the distance of S1 and S4 to the intersection:

$$l = t / v \quad (2)$$

Where: t is the time to report before the train to an intersection, v is medium speed of the train.

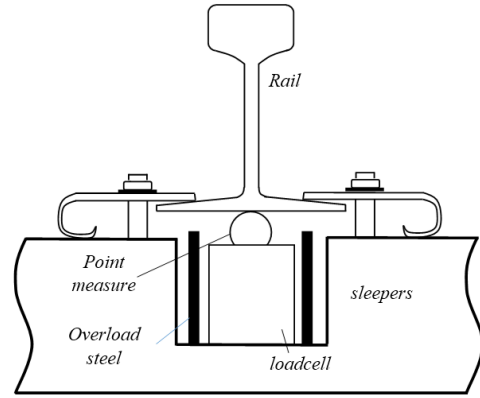

Fig. 4 Installing sensor between sleepers and rails

To recognize the working state of the sensors, when there are no trains, the sensors subject to the impact mass of the rails (about 0.5 tons) as shown in figure 4, this signal provides information that works well. When there is a train, the sensor subjected to the mass impact of the train and rails, this signal provides the train's information.

The loadcells are supplied with 12V DC power, the output signal varies from 0 - 240mV. To send this signal to the controller, we need to amplify the low voltage to the high voltage. The signal amplifier circuit diagram as shown in Figure 5:

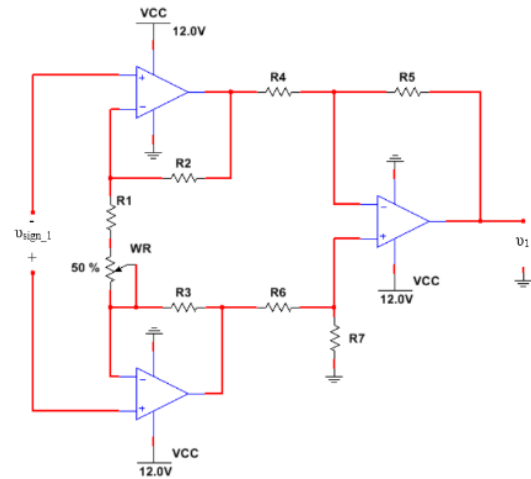

Fig. 5 The signal amplifier circuit from a load sensor

Voltage is calculated by [7]:

$$V_1 = \frac{R1 + R2 + R3 + WR}{R1 + WR} \cdot \frac{R5}{R4} \cdot U_{sign_1} \quad (3)$$

with $R4 = R6, R5 = R7$.

The signal from the loadcell v_{sign_1} follows through the amplifier circuit to be the signal v_1 volt. We use two comparative circuits to distinguish the signals: When the train is not transmitting v_{11} , this signal is to determine the active sensor; when the train is transmitting v_{12} , the threshold level can be adjusted experimentally. These signals are transmitted at 12V DC voltage. In case of sensor failure, the signal transmission 0V. To prevent lightning on the line, we use optical isolators. The signal transmitter circuit diagram as shown in Figure 6:

The program of the train alarm controller on the PLC uses the MicroWin software as following:

Table 1. Assigning the input address

| Symbol | Address | Meaning |
|--------|------------|--|
| S1 | I0.0 | Input, recognizing the train will come from the left. |
| S2 | I0.1 | Input, recognizing the train passing through an intersection from the right. |
| S3 | I0.2 | Input, recognizing the train passing through an intersection from the left. |
| S4 | I0.3 | Input, recognizing the train will come from the right. |
| | Q0.0, Q0.1 | Output, control the signal of the alarm system. |

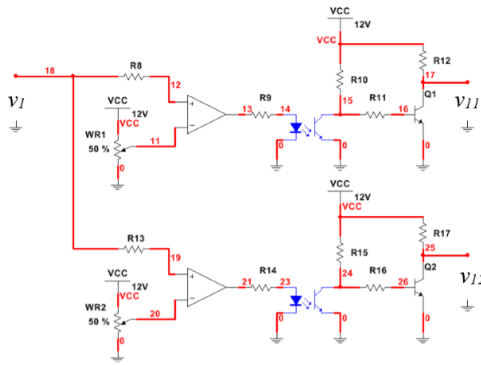

Fig. 6 The signal transmitter circuit

The signals v_{11} and v_{12} are transmitted to the control box by cables according to the standards of the railway sector.

B. The control box to alarm the train

To ensure the reliability of the signal control system when the train is going to the intersection, the team uses Siemens S7-200 CPU224 (16DI, 8DO) PLCs controllers. The controller receives signals from the sensor system, controlling the signaling the devices when the train arrives. In addition, there is a fault alarm function for the sensor system, which will help the manager to know if the sensor is damaged and damaged location. We use Arduino in conjunction with the Sim module to transmit the signal by mobile waves to the manager.

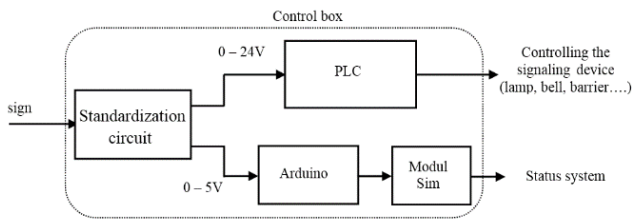

Fig. 7 Block diagram of the control box

The signal when there is train and not (v_{01} and v_{02}) is transmitted over a long underground cable (hundreds of meters), causing the voltage drop when the signal is transmitted to the controller. In addition to input signals of the PLC and Arduino are different, so we need to standardize the signal to 0V or 24V for the PLC and 0V or 5V to the Arduino before the signal to the controller. The signal standardization circuit is shown in Figure 8.

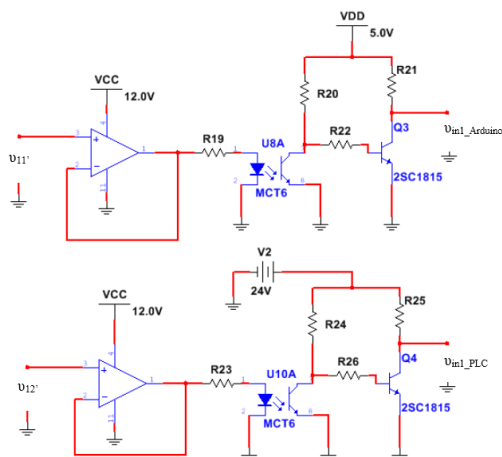

Fig. 8 The input signal standardization circuit of the controller

```

Network 1
LD SM0.0
R Q0.0, 2
R T5, 1
Network 2
LD I0.0
S Q0.0, 2
Network 3
LD I0.1
O I0.3
EU
S Q0.0, 2
Network 4
LD I0.2
O Q0.4
ED
R Q0.0, 2
Network 5
LD Q0.0
TONR T5, 1200
Network 6
LD T5
R Q0.0, 2
    
```

The algorithmic flowchart for sensor states is following:

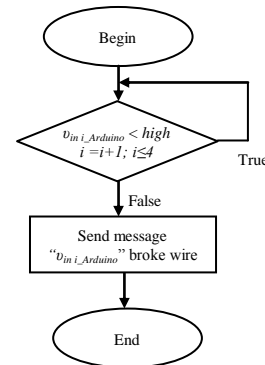

Fig. 9 Algorithm block diagram to check the state of the sensor system

III. RESULTS

Images of the real circuit:

Table 2. Parameters of resistance values

| | | | |
|-------------|----------|----------|------------|
| R1 = 10 kΩ | R8 = kΩ | R15 = kΩ | R22 = kΩ |
| R2 = 100 kΩ | R9 = kΩ | R16 = kΩ | R23 = kΩ |
| R3 = 100 kΩ | R10 = kΩ | R17 = kΩ | R24 = kΩ |
| R4 = 10 kΩ | R11 = kΩ | R18 = kΩ | R25 = kΩ |
| R5 = 100 kΩ | R12 = kΩ | R19 = kΩ | WR = 50 kΩ |
| R6 = 10 kΩ | R13 = kΩ | R20 = kΩ | |
| R7 = 100 kΩ | R14 = kΩ | R21 = kΩ | |

Designing the automatic train alarm system at the railway intersection

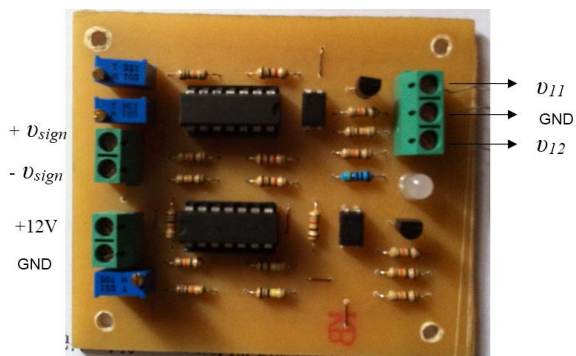

Fig. 10 The amplifier and signal transmitter circuit



Fig. 11 Inside of control box

IV. CONCLUSIONS

Automatic barrier systems are important, especially for countries with dense rail networks. The application and dissemination of these systems, in addition to contributing to the reduction of traffic accidents, will in the long run also reduce the cost of the railway sector (reduced staff, guard stations ...). The proposed topic uses load cells instead of specialized sensors and constantly updates the working status of the system, thus reducing the cost and time of troubleshooting. These barrier systems can also be connected online, controlled and monitored over the internet, which increases the safety of railway traffic.

ACKNOWLEDGMENT

The authors express their thanks for the support from **Thai Nguyen University of Technology**

REFERENCES

- [1] <http://timesofindia.indiatimes.com>.
- [2] <http://www.hindustantimes.com/india>.
- [3] <http://www.slideshare.net/dorismmahoney/common-causes-of-train-accidents-22193684>.

- [4] <http://www.forbixindia.com/electronics/products/traffic-light-control/unmanned-railway-crossing-alarm>.
- [5] <http://www.bombardier.com/en/transportation/products-services/rail-control-solutions.html>
- [6] <http://www.vienthongtinhieuduongsat.com>.
- [7] Adel S.Sedra, Kenneth C.Smith (2004) "Microelectronic Circuits", Oxford University, 81-89.
- [8] <http://www.railone.com>.
- [9] <http://www.vetek.com/Dynamics/Documents/22e3f563-dae1-4f0b-8a2a-be92a6108227/DATASHEET%20VZ266.pdf>
- [10] <http://smp17.all.biz>