

Instrumentation of Concrete Dams

Mathur R K., Sehra R. S., Gupta S. L.

Abstract— Instrumentation for dams is mainly required for two purposes, to compare the parameters during actual execution of project with the parameters designed and to detect any unusual or abnormal behavior of structure during construction and post -construction so that any future hazards can be predicted. Instrumentation may differ for different kind of dams. Instrumentation for concrete dams is needed to monitor performance of mainly concrete super structure and foundation. Proper instrumentation plan can evaluate actual behaviour of dam and its pertinent structures. This paper briefly discusses instrumentation of concrete dam along with specific parameters to be monitored, instruments required and frequency of instrumentation for different parameters. A case study of instrumentation is also discussed.

Index Terms— Alkali Aggregate Reaction, Crack Movement, Deformation, Piping.

I. INTRODUCTION

Dams are key structures of any hydro-project as they are designed to withstand enormous pressure created by impounding water. Sudden rise of impounded water pressure can result in loss of lives and property associated with the dam. Therefore, proper safety of dam is extremely important. To keep watch on safe performance of dam, regular monitoring of dam by implementing well planned instrumentation programme is imperative. Instrumentation along with visual observation can play vital role in providing early warning of many conditions that could lead to structure failures and other incidents. Detection of any unusual performance can be helpful in predicting any hazards and for taking remedial measures. Concrete, stone masonry or brick masonry are of heterogeneous type materials, but in designing it is assumed as homogeneous and isotropic. Therefore, states of stress and strain in the structure are different than assumed in design analysis. Proper instrumentation plan of any structure can be of great use in validating the structure's performance with design parameters. For concrete dams, instrumentation is basically done for monitoring the strength and elastic properties of concrete and foundation.

II. CAUSES OF CONCRETE DAMS FAILURES¹

Common factors affecting the performance of concrete dams are structural properties of the concrete and the foundation. These properties may be strength (compressive, tensile, and shear), elastic properties (modulus and Poisson's ratio) and its unit weight. Common causes of failures of concrete dams may be:

Mathur R K., Scientist 'D' Central Soil and Material Research Station, New Delhi

Sehra R. S., Scientist 'C' Central Soil and Material Research Station, New Delhi

Gupta S. L., Scientist 'E' Central Soil and Material Research Station, New Delhi

- Overtopping from inadequate spillway capacity.
- Spillway blockage resulting in erosion of the foundation at the toe of the dam
- Foundation leakage and piping in pervious strata.
- Rock discontinuities and sliding along discontinuities in foundations.

III. INSTRUMENTATION FOR CONCRETE DAMS

At the outset, it is necessary to appreciate that there is no standard instrumentation plan for any concrete dam. However, as per BIS code IS: 7436 (Part 2):1997² following obligatory and optional measurements are required to be provided for concrete masonry dams.

3.1 Obligatory Measurements

It include the uplift pressure at the base of dam, seepage, temperature (of dam, reservoir water and air), displacement (between two monoliths, between foundation and body of the dam), displacement of any joint of the dam with respect to surrounding set up.

3.2 Optional Measurements

They may be undertaken where warranted by special circumstances of the project, especially provided in high dams, mass concrete structure (MCS) with unusual design or with geological complexities. These measurements are sometimes taken for verification of design criteria, e.g., stress, thermal stress data, thermal response such as strains, pore pressure, seismicity of the area and dynamic characteristics of the structures.

IV. PARAMETERS TO BE MONITORED FOR CONCRETE DAMS

To know about performance of structure, common factors are required to be monitored and analyzed. These common factors may be temperature, water level, flow, precipitation, water quality etc. Apart from these common factors, some specific parameters are required to monitor for concrete dams.

As per ASCE guidelines³, following parameters for concrete dams are generally required to be monitored:

1.1 Concrete Temperature

Temperature changes cause concrete volume changes that affect contraction joints. It also affects growth of expansion in turn cracking in concrete caused by alkali aggregate reaction (AAR). Temperature measurements are important for a proper understanding of behaviour of dam as well as instruments installed on dam throughout the life of dam. Thermocouple, Thermistor an RTD are common devices for measurement of temperature.

1.2 Movement and Deformation of Dam

Movement can be linear or rotational and usually refer to a fixed point or rigid body while block monolith movement refers to relative movement of the blocks of a concrete dam. Commonly used instruments for measuring movements are plumb line, Inclinator, Laser plumb line and Tilt meter etc. Deformation strictly refers to change in position/ shape relative to the initial shape at a particular load or stress. Reservoir pressure or change in temperature causes deformation. Deformation can be measured by Normal and Inverted Plumb lines. With advancement in the field of instrumentation, nowadays Electronic Distance Measuring (EDM) instrument is being used for deformation of dam.

1.3 Crack Movement

Cracks are random discontinuities, whereas joints are predefined discontinuities. Almost all concrete structures cracks. There is no standard scheme for selection of instrument locations for measuring crack; however, instruments can be installed according to anticipation and assumptions of crack during design. For crack movement monitoring usually, crack width and/ or relative slip is measured. Crack movement can be measured by Crack meters/ Joint meters installing across the crack.

1.4 Uplift Pressure

Uplift pressure is referred as internal hydrostatic pressure acting on a horizontal section or at its base through the dam. It reduces vertical compressive stresses. Normally, uplift pressure is measured through piezometers or pressure gauge.

1.5 Seepage

Seepage is an important indicator of the performance of all types of concrete dams. The quantity of flow from foundation drains shows the effectiveness of drains in relieving foundation pressure. Normally, seepage is measured through Weir.

1.6 Stress and Strain

Stress monitoring is important in understanding the behaviour of concrete dams and their foundations. Stress can be measured directly by installing Stress meters. Strain can be easily measured by strain gauges. Stresses can also be calculated from strain if mechanical properties (modulus of elasticity and Poisson’s ratio) of concrete are known. However, the stress measuring instruments are more expensive and delicate than strain meters and hence, it is a common practice to measure the strain and developed stresses can be calculated from strain.

1.7 Seismic Force

Seismic monitoring of dams generally refers to two kinds of measurements, measurements of strong ground motions with accelerometers and measurement of ground motions with seismograph.

V. INSTRUMENTS RECOMMENDED FOR CONCRETE DAMS

The type, number, range, accuracy etc. of instruments instrument should be installed at such locations that serves the purpose effectively. Figure 1 shows typical concrete gravity dam with location of instruments.

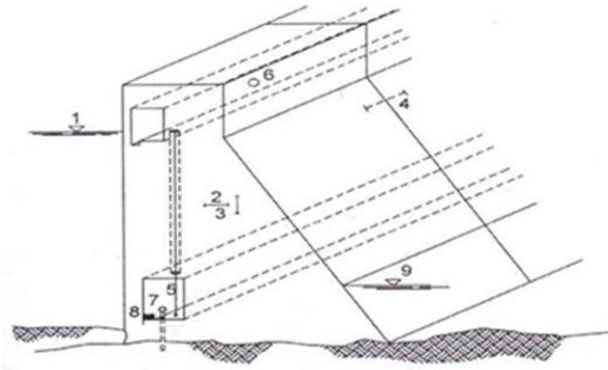

- 1 Measurement of Reservoir Level
- 2 Measurement of strain to determine stress
- 3 Measurement of internal temperature
- 4 Measurement of joint movement
- 5 Plumblines to measure movement
- 6 Fixed tilt meter
- 7 Measurement of uplift pressure at rock-concrete interface
- 8 Foundation Seepage measurement in gallery
- 9 Measurement of tail water

Fig 1: Location of instruments in a Concrete Gravity Dam³

Table 1 shows instruments for monitoring of different parameters for concrete dams as per ASCE guidelines.

Table 1: Concrete dam instruments and measurements (ASCE Guidelines)³

Property Measured	Measurement Location	Typical Instruments
Alignment	Crest or other surface location of interest	Total station, laser, GPS, Geodimeter
Rotation	Within concrete	Inclinometer
	Within foundation	Tiltmeter
Differential Movement	Across joints or cracks	Strain gauge, extensometer, joint meter, crack meter.
	Within foundation	Extensometer, tiltmeter
Water Pressure	Uplift across base	Piezometer, observation well
	Within concrete	Piezometer
	At drains	Pressure gauge
Stress and Strain	Foundation	Total pressure cell, load cell, strain meter, flat jack
	Within concrete	Total pressure cell, strain meter
Internal Temperature	Within concrete	Thermocouple, RTD, thermistor.
Seepage Quantity	Any location of interest	Calibrated container, weir, flume, flow meter.
Seepage Quality	Any location of interest	Turbidity meter
Anchor Load Retention	Anchor head	Load cell, jack and pressure gauge.
Earth quake Response	Crest, free field or other surface location of interest	Strong motion accelerometer

Instrumentation of Concrete Dams

[5] "Concrete Dam Instrumentation Manual" A Water Resources Technical Publication, United States Department of the Interior, Bureau of Reclamation. Page no.17.

[6] "Instrumentation of Dams" CBIP, publication no.287. Page no.318, 329-332.

Appendix-I⁵

Suggested minimum frequency of readings¹

Type of Instruments	During Construction		During Initial Filling	Periodic Report of Operation		
	Construction	Shutdown		Frist Year	2 to 3 Years	Regular
Vibrating-wire piezometers	Weekly ²	Monthly	Weekly	Biweekly	Monthly	Monthly
Hydrostatic uplift pressure pipes	Weekly	Monthly	Weekly	Weekly	Biweekly	Monthly
Porous-tube piezometers	Monthly	Monthly	Weekly	Weekly	Monthly	Monthly
Slotted-pipe piezometers	Weekly	Monthly	Weekly	Weekly	Biweekly	Monthly
Observation wells	Weekly	Monthly	Weekly	Weekly	Biweekly	Monthly
Water levels	Weekly	Monthly	Weekly	Weekly	Monthly	Monthly
Seepage measurement (weirs, flumes, etc.)	-	-	Weekly	Weekly	Biweekly	Monthly
Visual seepage monitoring	Weekly	Weekly	Weekly	Weekly	Biweekly	Monthly
Resistance thermometers	Twice weekly	Monthly	Weekly	Weekly	Monthly	Monthly
Thermocouples	Daily	Monthly	Weekly	Weekly	Monthly	Monthly
Carlson strain meters	Weekly	Weekly	Weekly	Biweekly	Monthly	Monthly ³
Joint meters	Weekly	Weekly	Weekly	Biweekly	Monthly	Monthly ³
Stress meters	Weekly	Monthly	Weekly	Biweekly	Monthly	Monthly ³
Reinforcement meters	Weekly	Monthly	Monthly	Monthly	Monthly	Monthly ³
Penstock meters	Weekly	Monthly	Monthly	Monthly	Monthly	Monthly ³
Deflectometers	Weekly	Monthly	Weekly	Weekly	Monthly	Monthly
Vibrating- wire strain gauge	Weekly	Monthly	Monthly	Monthly	Monthly	Monthly
Vibrating-wire total pressure cell	Weekly	Monthly	Monthly	Monthly	Monthly	Monthly
Load cell	Weekly	Monthly	Weekly	Biweekly	Monthly	Monthly
Pore pressure meters	Weekly	Weekly	Weekly	Biweekly	Monthly	Monthly
No-stress strain meters	Weekly	Weekly	Weekly	Biweekly	Monthly	Monthly
Foundation deformation meters	Weekly	Weekly	Weekly	Biweekly	Monthly	Monthly
Flat jacks	Daily	Weekly	Weekly	Biweekly	Monthly	Monthly
Tape gauges(tunnel)	Weekly	Weekly	Weekly	Biweekly	Monthly	Monthly
Whittemore gauges	-	-	Biweekly	Biweekly	Monthly	Monthly
Avongard crack monitor	Weekly	Monthly	Weekly	Weekly	Monthly	Monthly
Wire gauges	-	-	Monthly	Monthly	Monthly	Quarterly
Abutment deformation gauge	Weekly	Monthly	Weekly	Weekly	Monthly	Monthly
Ames dial meters	Weekly	Monthly	Weekly	Weekly	Monthly	Monthly
Differential buttress gauges	Weekly	Monthly	Weekly	Weekly	Monthly	Monthly
Plumbblines	Daily	Weekly	Daily	Weekly	Biweekly	Monthly
Inclinometer	Weekly	Weekly	Weekly	Weekly	Biweekly	Monthly
Collimation	Every other day for a month	Monthly	Weekly	Biweekly	Monthly	Monthly
Embankment settlement points	-	-	Monthly	Bimonthly or six times per year	Quarterly	Two times per year
Level points	Monthly	Quarterly	Monthly	Monthly	Six times per year	Six times per year
Multipoint extensometers	Weekly	Monthly	Weekly	Monthly	Monthly	Two times per year
Triangulation	-	-	Monthly	Monthly	Quarterly	Quarterly
Trilateration(EDM)	-	-	Biweekly	Monthly	Quarterly	Quarterly
Reservoir slide monitoring systems	-	-	Monthly	Monthly	Monthly	Quarterly
Power plant movement	-	-	Weekly	Monthly	Monthly	Monthly
Rock movement	Weekly	Monthly	Weekly	Monthly	Monthly	Monthly

¹These are suggested minimum; however, anomalies or unusual occurrences such as earthquakes or flood will require additional readings.

²Daily during curtain grouting.

³May be discontinued after 3 years unless anomalies are noted.

(Ref: Concrete Dam Instrumentation Manual; A water resources Publication , United States Department of the Interior, Bureau of Reclamation, October,1987,Table 1-3,Page no.9