

# Implementation of Real Time Video Streamer System in Cloud

Mrs.G.Sumalatha, Mr.S.Bharathiraja

**Abstract**— In this paper, Embedded Real-time video monitoring system is designed, in which the embedded chip and the programming techniques are used. The central monitor which adopts Raspberry pi is the core of the whole system. Real time video transmission is widely used in surveillance, conferencing, media broadcasting and applications that include remote assistance. First, USB camera video data are collected by the embedded Linux system. All data are processed, compressed and transferred by the processing chip. Then, video data are sent to the mobile client by wireless network. This embedded monitoring system to overcome the weak points of the traditional video surveillance systems, such as complex structure, poor stability, and expensive cost. It can be widely used in many fields, and also used for long distance transmission.

**Index Terms**— Video Capture, Video Compression, Video Streaming, Raspberry Pi, Embedded Linux

## I. INTRODUCTION

In recent years, there has been an increase in video surveillance systems in public and private environments due to a heightened sense of security. The next generation of surveillance systems will be able to annotate video and locally coordinate the tracking of objects while multiplexing hundreds of video streams in real-time. Video surveillance has been evolving significantly over the years and is becoming a vital tool for many organizations for safety and security applications [5]. Detection and tracking of moving objects are important tasks for computer vision, particularly for visual based surveillance systems. Video surveillance application, most times imply to pay attention to a wide area, so unidirectional cameras or mobile cameras are generally used [6]. In this system, we use the Raspberry pi chip as the microprocessor. Video data is captured from a USB camera or Raspberry pi camera, compressed into MPEG format, transferred the 3G network under the control of the ARM11 chip; then, the monitor client will receive the compressed data frame to restructure, and recompose video images. Wireless video monitor system provide a practical solution for remote wireless monitoring with low cost.

The concept of video stream becomes invalid due to the mesh topology. The basic data unit in this kind of systems is video chunk. The multimedia server divides the media content into small media chunks of a small time interval, each of them with a unique sequence number that serves as a sequence identifier. Later, each chunk is disseminated to all peers through the mesh. Since chunks may take different paths in order to reach

a peer, they may arrive to destination in a non-sequential order. To deal with this matter, received chunks are normally buffered into memory and sequentially rearranged before delivering them to its media player, ensuring continuous playback. There are two different ways to exchange data in mesh-based systems: push and pull. In a mesh-push system, a peer constantly pushes a received chunk to the rest of neighbours who need it. However, due to system topology, redundant pushes could be responsible for wasting peer uploading bandwidth. As a result, a mesh-pull system is used to avoid the situation described earlier. This technique allows peers to periodically exchange chunk availability according to buffer maps. A buffer map holds the sequence number of chunks currently available in a peer's buffer; this way a peer can decide from which peers to download which chunks, avoiding redundant chunk transmissions that were present using push. A disadvantage of the pull technique is that both frequent buffer map exchanges and pull requests produce more signalling overhead and introduce additional delays while retrieving a chunk. The Video surveillance systems play an increasingly important role to maintain social security. It has been widely used in many fields, such as finance, public security, banking, and home. Traditional video surveillance can generally achieve close distance monitoring, by using the PC as a monitor host, monitor host connected monitor camera with coaxial cable [1]. Initially, it was dominated by analogy cameras connected using coax cables. For cost and Performance reasons, there was a switch to digital switching systems and now IP-based delivery of data [5].

## II. HARDWARE SYSTEM DESIGN

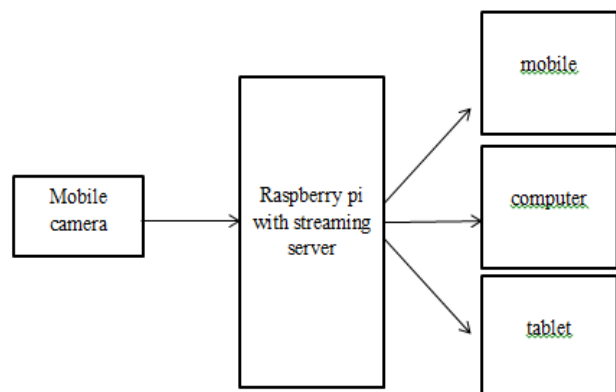

The hardware system includes processor, video -capture devices, and router to receive video information through Wi-Fi. In this project Raspberry pi (ARM11 processor) is chosen to complete the core control; Raspberry pi camera is used as a video-capture device; and the user's phone or PC connected to the wireless Internet to receive video information to achieve real-time monitoring.

Mrs.G.Sumalatha, Assistant Professors, Department of Information Technology, V.R.S College of Engineering & Technology

Mr.S.Bharathiraja, Assistant Professors, Department of Information Technology, V.R.S College of Engineering & Technology, Mob. No: 7339548580

Fig. 1: Block diagram of the hardware system design. Mobile-Camera: Raspberry pi camera is used as web-camera for capturing video. Raspberry pi[8]; Raspberry pi is used for hardware module. Raspberry pi is a credit card size Linux computer used for simple programming. The Raspberry Pi is a computer about the size of a credit card, designed to cost around Rs. 3K for the cheapest model. The board is designed with an intention of providing computer education to the remote schools where the PCs are not very commonly used (Figure 1). This includes a 700 MHz ARM11 processor; 128 or 256 MB of memory (RAM); there is also a memory card slot, audio/video outputs to connect to TV, and a USB port for keyboard, mouse and so forth. The brain of the Rasbpi is the Broadcom BCM2835 “system-on-a-chip,” which includes the main components needed for a computer system. These include the central processing unit (processor), which handles the main workload; the graphics processing unit (GPU), which accelerates the process of producing the complicated graphics you see on your screen; and the random access memory (RAM) which acts as somewhere for the CPU to keep the information that it is working on.



Figure 2: Block diagram of Raspberry Pi  
 A. Router: Router is used for route the video streaming on network.  
 B. PC/Mobile: Pc/Mobile is used for to watch live video streaming on server.

### III. SOFTWAREDESIGN

However, the tradition mode has many disadvantages with the increased requirements. Nowadays, embedded device has played an important role in many applications such as equipment control. Embedded device has outstanding character for its small size and more mobility. In our system, we combine the wireless communication and embedded device together. As for EOS (Embedded Operating System), we select the embedded Linux as our bottom system. But today in this digital world, the embedded video surveillance systems are more advantageous compared to the traditional surveillance systems, as it is provided at low cost with high performance and good stability[2]. Generally, as a specific kind of computer system, embedded system is made up of hardware, embedded operating system and user application program. Hardware consists of embedded CPU and external devices. Embedded

CPU is the core of the embedded system. There are some popular embedded CPU architectures such as MIPS, PowerPC, ARM, etc. External devices provide assistant functions to CPU. In terms of functions, external devices are classified into memory devices (RAM, SRAM, Flash, etc), communication devices (RS-232 interface, SPI interface, Ethernet interface, etc), display devices (LCD) [2]. Embedded device has its own specific problems to consider: such as the energy consumption, the capability of data computing, the complexity of algorithm, etc. According to the features of embedded device, there exist some EOSs such as Wince, VxWorks, Palm OS, embedded Linux, etc. Compared to the other, embedded Linux operating system has many advantages:

- Lower costs.
  - Applied to many hardware platforms (such as PowerPC, X86, ARM).
  - Tailored Linux kernel.
  - Relatively better performance – Better network support.
- In terms of software, embedded Linux operating system can be divided into four layers:

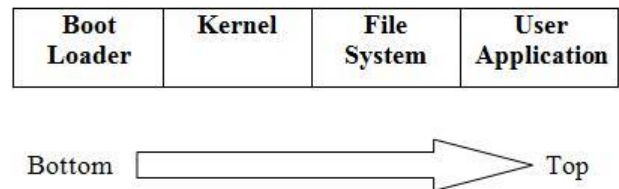

Fig. 3: Four layers of embedded Linux operating system.

Boot loader is executed first when the system starts. Boot loader initializes the hardware circuit and prepares for the launch of Linux. The implement of Boot loader depends on the specific embedded CPU architecture. Now there are two kinds of boot loader: vivi and uboot[2]. Kernel is the core of the embedded Linux operating System. All of the hardware resource is controlled by kernel.

Kernel manages jobs as follow:

- System call interface.
- Process control.
- Memory management.
- File system management.
- Device drivers.

File system is a layer between user application and the kernel. It helps user application to communicate with the kernel and provides bottom hardware information. User application could only invoke the functions offered by the file system, such as standard C functions.

### IV. OVERVIEW OF THE RASPBERRY PI

#### Raspberry Pi hardware

The picture of Raspberry Pi is shown in Fig. 1. A normal web camera is used for live video capturing. The connections are also shown in the picture. This system proposed here uses Raspberry Pi Model B connected to a Logitech C300 universal serial bus (USB) webcam. Power supply required by the device is 3V DC which is being converted first from 5V DC. External hard drive is required for data storage. Here 16 GB Secure Digital High

Capacity transcendent card is used. Internet connection is being provided via CAT6 Ethernet cable. The camera module is being attached to the stepper motor which is being controlled through the device. This is done to ensure that camera captures images in all directions. Raspberry Pi model is an ARM 9 processor with description and further specifications are shown in the table below.

### Raspberry Pi Software

During initial setup Raspberry Pi was configured as a miniature desktop with USB configured camera module and an external monitor or mobile for viewing the captured video. Browser is used for viewing of live video stream. The external card is loaded with Raspbian OS. The Dynamic host Protocol is obtained for Raspberry Pi i.e IP address is fetched. After obtaining this the system can be configured and controlled remotely. The live video can be viewed by dialling-in the IP address into a web browser. Cost of the whole system is \$70. Cost of Raspberry Pi is less as compared to other alternatives. We can calculate the cost-per-mega-pixel and conclude that image resolution on remote screen by raspberry pi is 960x720 (0.7 megapixels) and cost-per-megapixel image is as approximately is \$125.

## V. IMPLEMENTATION

The project components which include raspberry pi, web camera, monitor/mobile for display are shown in figure.

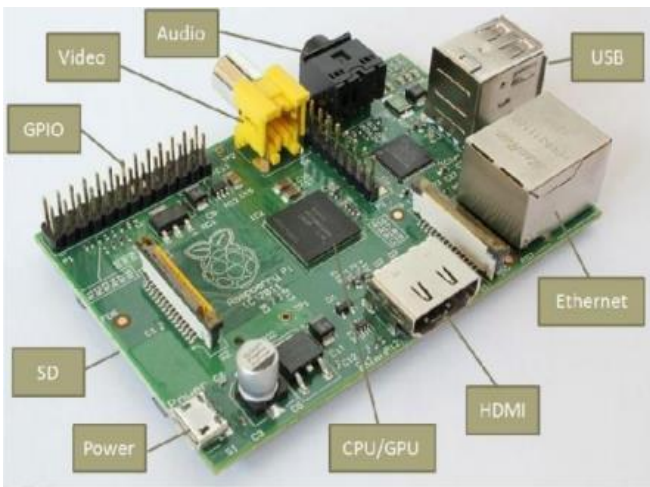

there are number of different ports available on raspberry pi such as video, audio as output ports, USB port for external device connection like camera, Ethernet port for net connection (i.e. Wifi module), HDMI port which is used for both audio and video(works with modern TVs and DVI monitors), power connection port requires 5V power supply.

### SOFTWARE ARCHITECTURE

The system selected Linux operating system as software platform, use embedded Linux 2.6 kernel. And there are mainly three function modules, that is, Video capture module, Video Compression module, and Video Streaming module. The flow chart of software system is shown below.

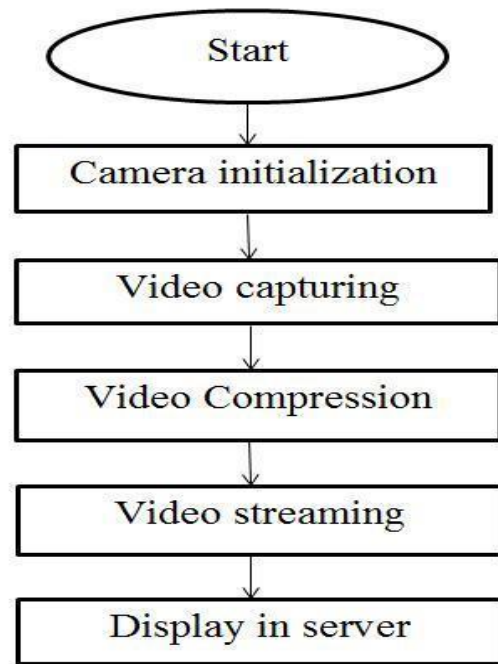

Figure 4: Flow chart of software system.

### A. Video Capture Module

Video Capture Based Video4Linux (referred to as "V4L") is a Linux kernel on the video device driver, which is for video equipment, application programming interface functions to provide a system. V4L USB camera using the programming on the need to use Linux system calls the next two, respectively, ioctl() and mmap(). Application to get the camera image data collected in two ways, namely read() (method of direct reading) and mmap() (memory mapping method). mmap() system call allows processes mapping the same file through memory sharing achieved, the advantages of high efficiency, because the process can directly read and write memory, copy any data without the need to speed up the I/O access, the system is Using this method.

**B. Video Compression** The increasing demand to incorporate video data into telecommunications services, the corporate environment, the entertainment industry, and even at home has made digital video technology a necessity. A problem, however, is that still image and digital video data rates are very large, typically in the range of 150Mbps/sec. Data rates of this magnitude would consume a lot of the bandwidth, storage and computing resources in the typical personal computer.

For this reason, Video Compression standards have been developed to eliminate picture redundancy, allowing video information to be transmitted and stored in a compact and efficient manner.

**C. Mpeg (Motion Picture Experts Group)**MPEG-2 is a standard for "the generic coding of moving pictures and associated audio information". It describes a combination of loss video compression and loss audio data compression methods, which permit storage and transmission of movies using currently available storage media and transmission bandwidth [9]. MPEG-2 is widely used as the format of digital television signals that are broadcast by terrestrial (over-the-air), cable, and direct broadcast satellite TV systems. It also specifies the format of movies and other programs that are distributed on DVD and similar discs. TV stations, TV receivers, DVD players, and other equipment are often

designed to this standard. MPEG-2 was the second of several standards developed by the Moving Pictures Expert Group (MPEG) and is an international standard (ISO/IEC 13818). Parts 1 and 2 of MPEG-2 were developed in collaboration with ITU-T, and they have a respective catalog number in the ITU-T Recommendation Series.

**D. Mpeg-2 Compression Algorithm** [1] MPEG-2 provides for flexibility in the type of compression. Encoders can vary considerably depending upon the application, so details of the encoding scheme must be transmitted along with the data, to enable the decoder to reconstruct the signal. First a reduction of the resolution is done, which is followed by motion compensation in order to reduce temporal redundancy. The next steps are the Discrete Cosine Transformation (DCT) and a quantization as it is used for the JPEG compression; this reduces the spatial redundancy (referring to human visual perception). The final step is an entropy coding using the Run Length Encoding and the Huffman coding algorithm.

**E. Video Streaming** Once RGB web camera is connected through master USB interface to arm board make minicom-s settings in the terminal window, during the settings we run the application related shell script in terminal which will execute application in board resulting video streaming on web browser using http protocol, entering a static IP address by user in any wireless device which is in local network can view the remote location. Here the web browser is based on MJPG streamer for streaming captured video from camera placed in remote location. The MJPG streamer is cross compiled and loaded in to the Raspberry pi board to act as a web streaming server. The server periodically obtain videos from camera through the private network, such videos are transmitted from camera to the server.

### VI. DISPLAY VIDEO ON SERVER

We can access live stream from camera from any browser with the help of URL. <http://192.168.137.50:8080> Here 8080 is port where we configuration our stream in motion. Conf file. We can see our own configuration setting "stream port" in motion.conf for port. We have found that Google chrome 30 is not able to play the stream directly due to bug in the chromium project. We can get a large image with the stream URL of the camera. And also we were not able to watch live stream in internet explorer because it does not support motion jpeg. Any other browser like Firefox, safari and also vlc media player was able to show live stream. After filling proper URL we can see video streaming with small delay.

### VII. CONCLUSION

In this paper, an embedded real-time video monitoring system is designed; the embedded web streaming server is based on the Linux Operating System. It succeeds in network video monitoring. The system has low-cost, good openness and portability and is easy to maintain and upgrade. Here the web browser is based on MJPG streamer for streaming captured video from camera placed in remote location. The MJPG streamer is cross-compiled and loaded in to the Raspberry pi board to act as a web streaming server. The server periodically obtain videos from camera through the private network, such videos are transmitted from camera to the server. We conclude that real time video monitoring using

arm we get better performance and we can transmit video using wire and also possible for wireless hence long distance transmission is possible.

### REFERENCES

- [1] D. Jeevanand, K. Keerthivasan, J. Mohamed Rilwan, P. Murugan "Real Time Embedded Network Video Capture And SMS Alerting system" International Journal of Communication and Computer Technologies, 2014.
- [2] Kavitha Mamindla, Dr. V. Padmaja, CH. Naga Deepa, and "Embedded Real Time Video Monitoring System Using Arm", IOSR Journal of Engineering (IOSRJEN) eISSN: 2250-3021, p-ISSN: 2278-8719 Vol. 3, Issue 7 (July. 2013), ||V6 || Page(s) 14-18.
- [3] Zhou Zhe, "ARM-Based Embedded Linux System For Wireless Video Monitor applications", Department of Information Engineer, Beijing University of Post and Telecommunication, Beijing (100876), Page(s): 1-4.
- [4] G. Senthikumar, S. Ragu, N. Siva Kumar, "Embedded Video Surveillance with Real time Monitoring on Web", International Journal of Mathematics Trends and Technology-May to June Issue 2011 Page(s): 46-49.
- [5] Wei Chen, Chien-Chou Shih, Lain-Jinn Hwang, "The Development and Applications of the Remote Real-time Video Surveillance System", Tamkang Journal of Science and Engineering, Vol. 13, No. 2, Page(s): 215- 225 (2010).
- [6] Chingchun Huang, Chao-Chun Yeh, "Real-Time Video Surveillance over IEEE 802.11 Mesh Networks", Industrial Technology Research Institute (ITRI) Hsinchu, Taiwan, Arvind Kandhalu, Anthony Rowe, Ragnathan (Raj) Rajkumar, Department of Electrical and Computer Engineering Carnegie Mellon University, Pittsburgh, USA-15213, Page(s) 1-10.
- [7] G.L. Foresti and C. Micheloni, "Real-Time video surveillance by an Active Camera", Department of Mathematics and Computer Science (DIMI) University of Udine, Viadelle Scienze, 206, 33100 Udine, ITALY ,Page(s): 1-7.
- [8] Matthew Neil, Stones Richard. Beginning Linux Programming, 4th Edn. Wiley Publishing Inc, Indianapolis, Indiana. 2008.
- [9] [http://en.wikipedia.org/wiki/Raspberry\\_Pi](http://en.wikipedia.org/wiki/Raspberry_Pi).
- [10] <http://elinux.org/>
- [11] <http://www.raspberrypi.org/>