

# 3D Modeling of Temperature Distribution for Absorber Tube of Parabolic Trough Collector

Mya Mya Mon, Myat Myat Soe, Maw Maw Htay

**Abstract**— Solar Parabolic Trough Collectors (PTCs) are currently used for the production of electricity and applications with relatively higher temperature. In this work, temperature distribution of absorber tube for fluid flow in a parabolic trough collector is studied. Three dimensional temperature distribution of the absorber tube due to uniform heat flux is analyzed by numerically. This heat flux is determined based on 21<sup>st</sup> December of Mandalay which has the tropical climate in Upper Myanmar. Soltrace software is used to check the theoretical results of heat flux. Three types of fluid are used as heat transfer fluid and simulations are carried out k-ε model using Computational Fluid Dynamics CFD, COMSOL Multiphysics® 4.3b, for constant flow rate of fluid. It is observed that fluid is higher in temperature at the exit end of absorber tube with fluid flow rate of 0.5 m/s and solar flux condition of 938 W/m<sup>2</sup>.

**Index Terms**— parabolic trough collector, heat transfer fluid, absorber tube, heat flux, temperature distribution

## I. INTRODUCTION

In the present, solar technology for electricity generation can be made by various systems such as parabolic trough, parabolic dish, and Fresnel lens [21]. Among them parabolic trough collectors are the most installed plants around the world. Parabolic trough collector can be operated at temperature up to 450°C [12]. Concentrating solar collectors operate by using reflectors to concentrate sunlight on the absorber of a solar collector, the size of the absorber can be dramatically reduced, which reduces heat losses and increases efficiency at high temperatures. A parabolic trough collector system as illustrated in Fig. 1 is composed of a sheet of reflective material, usually silvered acrylic, which is bent into a parabolic shape. The long parabolic shaped modules have a linear focus (focal line) along which an absorber is mounted. A trough-shape parabolic trough mirror concentrates sunlight on the absorber tube which is placed at the focal point. The parabolic trough collector therefore suits for medium temperature conversion of solar radiation. The temperature rise depends on the geometrical concentration ratio and optical properties of the collector as well as fluid flow in the tube. Such studies are needed to find three-dimensional temperature distribution of the absorber tube. In this article, three dimensional temperature distribution of the absorber tube of LS-2 collector are determined numerically for various heat transfer fluid.

A parabolic trough collector includes the receiver tube, the

concentrator, power transmission, collector structure. The receiver is the element of the system where solar radiation is absorbed and converted to thermal energy. It includes an absorber tube and its associated glass cover [1]. The receiver is a key component of the parabolic trough solar plant. It plays an important role in the energy conversion of concentrated sunlight into fluid thermal energy through an absorber tube. The working fluid in the receiver tube absorbs solar energy and transfers it to water in heat exchangers to produce hot water steam. The receiver is covered by a glass tube to reduce thermal radiation as well as convection heat loss to the free air which moves round the receiver. To reduce further the heat losses from the absorber, air is evacuated from the space between absorber and glass cover.



Fig. 1 Parabolic trough collectors [2]

The absorber tube of parabolic trough collector consists of a heat absorption steel pipe, coated with a black chrome selective surface or a low thermal emittance cermet selective coating [19]. The absorber pipe is covered by an evacuated glass tube that is coated with antireflective coating on both surfaces. Therminol VP-1, Therminol VP-59 [17] and Syltherm 800 [18] are used as the collector heat transfer fluid. In order to determine the optimum size of a parabolic trough to increase the power of a solar thermal power plant system in Myanmar, the simulation was created as a tool to determine the optimum parameters for the parabolic trough. These parameters were input to the power plant. The performances of the solar collectors were studied to find the best shape of the absorber tube for the solar collector.

The scope of this paper is to determine temperature distribution of fluid flow in the receiver pipe by using common CFD software. Table 1 is dimensions of parabolic trough collector.

**Mya Mya Mon**, Department of Mechanical Engineering, Mandalay Technological University, Mandalay, Myanmar, +95933538170.

**Myat Myat Soe**, Department of Mechanical Engineering, Mandalay Technological University, Mandalay, Myanmar, +95943014802.

**Maw Maw Htay** Department of Mechanical Engineering, Mandalay Technological University, Mandalay, Myanmar, +959400503768.

### 3D Modeling of Temperature Distribution for Absorber Tube of Parabolic Trough Collector

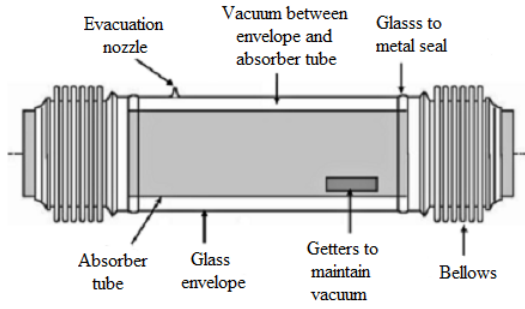

Fig. 2. Components of an absorber tube of parabolic trough collector [1]

TABLE I  
DIMENSIONS OF PARABOLIC TROUGH COLLECTOR [5]

Width of collector (W)	5 m
Length of collector (L)	7.8 m
Outer diameter of absorber tube ( $D_o$ )	0.07 m
Inner diameter of absorber tube ( $D_i$ )	0.066 m
Reflectivity of receiver	0.85

## II. MATERIALS AND METHOD

The heat flux of parabolic trough collector is analysed by theoretically and numerically to use as input data in three dimensional temperatures distribution of absorber tube of parabolic trough collector. The heat fluxes are considered for tropical climate of Mandalay in Myanmar. The heat flux results are calculated based on 21<sup>st</sup> December. Soltrace software is used to check the heat flux of parabolic trough collector. The heat flux of parabolic trough collector can be calculated by using the following equations. The effective solar constant can be calculated by using equation (1);

$$I_{0,eff} = I_0 \left[ 1 + 0.033 \cos \left( \frac{360}{365.25} \right) \right] \quad (1)$$

The declination can be defined as;

$$\delta = 23.45 \sin \left[ \frac{360}{365} (284 + n) \right] \quad (2)$$

The solar zenith angle between the vertical axis of the collector and the sun's ray direction can be calculated as;

$$\theta_z = \cos^{-1} [\sin \lambda \sin \delta + \cos \lambda \cos \delta \cos \omega] \quad (3)$$

The equation of beam radiation under clear sky conditions;

$$I_b = I_{0,eff} \left[ a_0 + a_1 \exp \left( \frac{-k}{\cos \theta_z} \right) \right] \quad (4)$$

The ratio of beam radiation is represented by;

$$R_b = \frac{\cos \theta}{\cos \theta_z} \quad (5)$$

The solar heat flux can be calculated;

$$S = I_b R_b (\tau \alpha)_b \left( \rho \gamma + \frac{D_o}{W - D_o} \right) \quad (6)$$

The calculated results of heat flux are compared by using Soltrace. Fig. 3 shows the comparison of heat flux. Performance of PTC completely depends on the absorber tubes through which working fluid flows and on which all the solar energy is focused. In the present research COMSOL Multiphysics® 4.3b is used to carry out the CFD simulations. Model consists of a hollow absorber tube through which fluid is flowing. Simulations of absorber tube for three types of fluid are carried out.

Geometry of the tube can be built in COMSOL Multiphysics®. The outer diameter of the tube is 0.07 m and inner diameter is 0.066m of 1 m length.

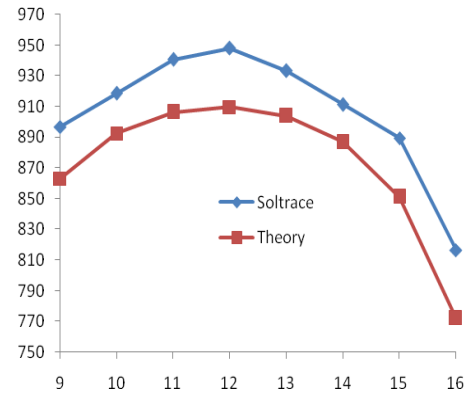

Fig. 3. Comparison of heat flux

Physics used for the simulations is Non-isothermal turbulent flow, which is generally used for modelling of heat transfer in fluids, but it is also provides the flexibility for heat transfer is solid. The analytical model includes the fundamental mass, momentum and energy conservation equations associated with two transport equations for k-ε model to calculate the turbulent energy production, k and the turbulent energy dissipation, ε.

Some assumptions are adopted for this analysis:

1. The flux distribution is assumed to be uniform over the surface of the tube.
2. The fluid flow is assumed to be fully developed and incompressible.
3. Steady state heat transfer is considered so that the heat flux at the wall does not change.

The thermal conductivity of the absorber tube and material is uniform and constant.

The boundary conditions are set to be wall function for all walls, velocity and temperature for the inlet and zero pressure gradient condition is applied for the outlet boundary. The simulations are carried out for three types of heat transfer fluid by using the same velocity for inlet boundary. The inner surface of the absorber tube is contact with the oil flow with a convection coefficient of h which is determined analytically [16]. As example, at the temperature of 373 K and oil velocity of 0.5 m/s, h is determined from following equations.

$$Re = \frac{vD}{\nu} \quad (7)$$

$$Pr = \frac{\mu C_p}{k} \quad (8)$$

$$Nu = \frac{\left(\frac{f}{8}\right)(Re-1000)Pr}{1+12.7\left(\frac{f}{8}\right)^{1/2}\left(Pr^{2/3}-1\right)} \quad (9)$$

$$h = \frac{Nu \times k}{D} \quad (10)$$

Therminol VP-1, Therminol VP-59 and Syltherm 800 are used as fluid. Thermophysical properties of these fluids are shown in Table 3. To avoid complications, only single phase flows is considered. On the outer surface of the absorber tube heat flux is provided.

TABLE II  
THEORETICAL RESULTS OF CONVECTION HEAT TRANSFER COEFFICIENT

Type of (HTF)	Re (10 <sup>4</sup> )	f	Nu	h (W/m <sup>2</sup> -K)
Therminol VP1	3.35	0.02299	302.7923	587.2335
Therminol Vp59	2.29	0.02523	259.4799	452.1241
Syltherm 800	0.917	0.03222	142.7227	259.3876

Mesh size for COMSOL model is kept normal for larger areas and fine for smaller areas to reduce the computational times. Heat flux value is considered 938 W/m<sup>2</sup> which is calculated based on tropical climate of Mandalay, Myanmar of 21<sup>st</sup> December. The fluid flow has been considered 0.5 m/s and the temperature of inlet of the absorber tube has been considered 373 K. The calculated results of convection heat transfer fluid are shown in Table 2. Numerical solution is carried out only for the absorber tube.

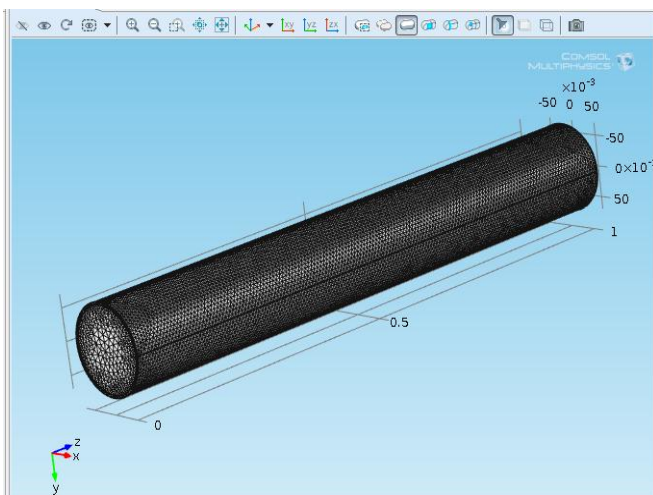

Fig. 4. The generated grids of absorber tube

TABLE III

THERMOPHYSICAL PROPERTIES OF HEAT TRANSFER FLUID [17, 18]

Parameter	Therminol VP-1	Therminol VP-59	Syltherm 800
Density (kg/m <sup>3</sup> )	999	915	864
Specific heat (J/kg-K)	1775	1940	1745
Viscosity (mPa-s)	0.985	1.32	3.11
Thermal conductivity (W/m-K)	0.128	0.115	0.11995

### III. RESULTS AND DISCUSSION

The heat flux of parabolic trough collector is evaluated by using Microsoft Excel based on the location of Mandalay, Upper Myanmar that has tropical climate. The 21<sup>st</sup> December is considered for studying the system performance as clear day. The theoretical heat flux is compared with Soltrace software. It is shown in Fig. 3. Fig. 5 is a intersection of parabolic trough collector and flux intensity of contour plot for parabolic trough collector is shown in Fig. 6.

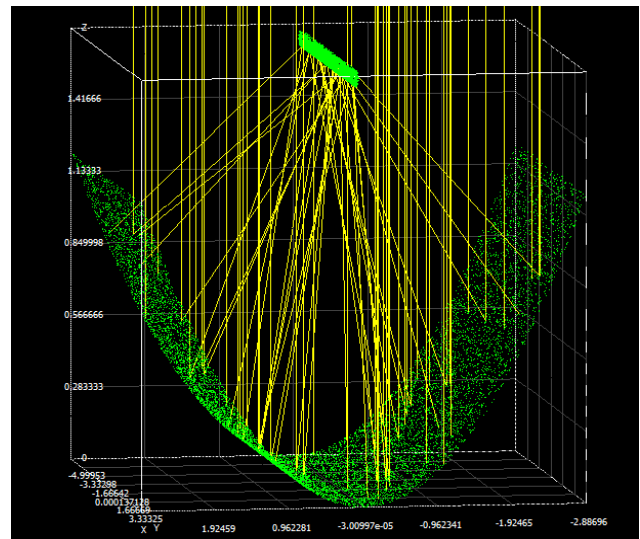

Fig. 5. Intersection plot of parabolic trough collector

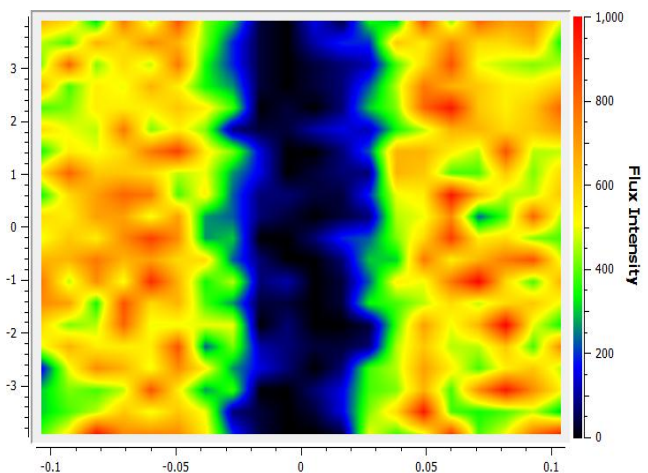

Fig. 6. Contour Plot for the Parabolic Trough

### 3D Modeling of Temperature Distribution for Absorber Tube of Parabolic Trough Collector

Modelling is performed the steady state temperature distribution of the absorber tube is determined by using COMSOL software. For the specified absorber tube and collector specification, temperature distribution is determined for three types of heat transfer fluid. Typical 3D views of the temperature distribution of absorber tube are shown for inlet fluid temperature of 373 K and flow velocity of 0.5 m/s. Temperature distribution of Therminol VP-1, Therminol VP-59 and Syltherm 800 fluid along the length of the absorber tube are shown in Fig. 7, 8 and 9, respectively. Determination of the turbulent quantities and treatment of the boundary layers near the wall surfaces of our model were attempted by solving the transport equations of realizable k-ε model.

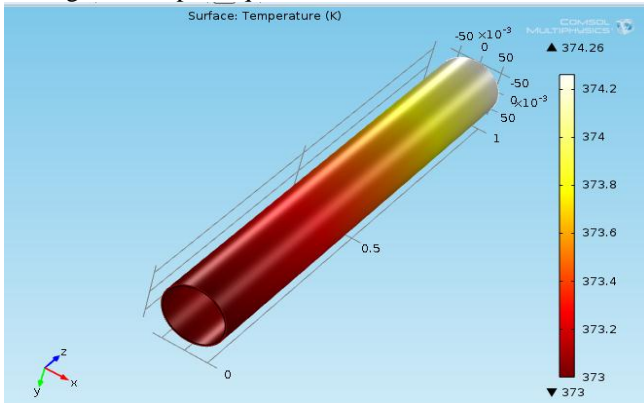

Fig. 7 Temperature distribution for Therminol Vp1 fluid

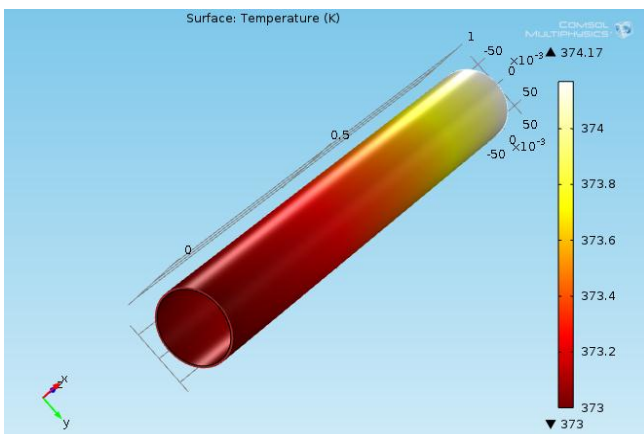

Fig. 8. Temperature distribution for Therminol VP 59 fluid

As the thickness of the absorber tube of the modelled collector is reasonably thin, the tube thermal conductivity may have no significant influence on the thermal phenomenon as can be noted from [11].

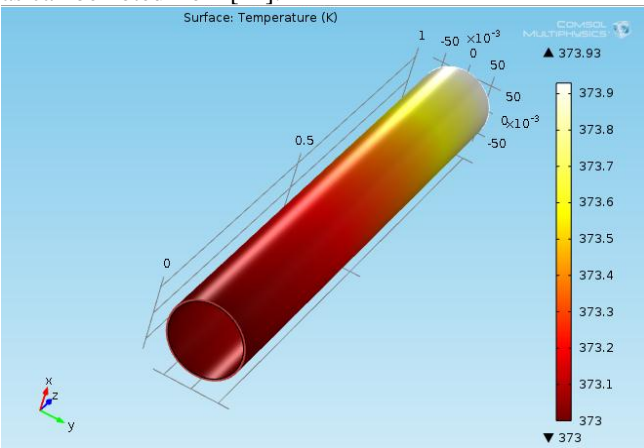

Fig. 9. Temperature distribution for Syltherm 800 fluid

The boundary conditions assumed for the model are inlet temperature as 373 K and velocity of fluid as 0.5 m/s, respectively. Other boundary conditions like density, specific heat, thermal conductivity and other material properties are considered as constants throughout the analysis. The outer surface of the absorber tube is given constant wall heat flux 938 W/m<sup>2</sup>. The heat transfer takes place from the wall surface of the absorber tube to the fluid.

TABLE IV  
OUTLET TEMPERATURE FOR THREE TYPES OF HEAT TRANSFER FLUID

S. No.	Types of Heat Transfer Fluid	T <sub>in</sub> (K)	T <sub>out</sub> (K) (Theoretically)	T <sub>out</sub> (K) (Numerically)
1	Therminol VP1	373	373.6	374.26
2	Therminol VP59	373	373.5	374.17
3	Syltherm 800	373	373.7	374.92

#### IV. CONCLUSIONS

In this paper, the heat flux of parabolic trough collector is investigated by theoretically and numerically based on 21<sup>st</sup> December of Mandalay, Myanmar. The peak flux occurs at noon is 938 W/m<sup>2</sup>. This value of heat flux is used as input data to analyze three dimensional temperature distribution of absorber tube for parabolic trough collector. Three dimensional modeling of temperature distribution for a parabolic trough thermal collector receiver is performed based on some simplified assumptions by using COMSOL Multiphysics® software, which is reported in this article. In this paper, the three heat transfer fluids are compared with same material of absorber tube. The outlet temperature of Therminol VP1, Therminol VP59 and Syltherm 800 are 374.26 K, 374.17 K and 374.92 K, respectively. According to these results, the outlet temperature of Syltherm 800 fluid is the most suitable for solar thermal power plant. The three dimensional numerical analysis is able to predict the fluid flow and heat transfer characteristics through the absorber tube.

#### REFERENCES

- [1] Ketan Diwan, M.S. Soni\*, "Heat Transfer Enhancement in Absorber Tube of Parabolic Trough Concentrators Using Wire-Coils Inserts," Universal Journal of Mechanical Engineering 3(3): 107-112, 2015.
- [2] M. Natarajan, R. Thundil Karuppa Raj, Y. Raja Sekhar, T. Srinivas and Pranay Gupta, "Numerical Simulation of Heat Transfer Characteristics in the Absorber Tube of Parabolic Trough Collector with Internal Flow Obstructions," ARPN Journal of Engineering and Applied Sciences, Vol. 9, No. 5, May 2014.
- [3] M. Yaghoubi, F. Ahmadi, and M. Bandehee, "Analysis of Heat Losses of Absorber Tubes of Parabolic Trough Collector of Shirz (Iran) Solar Power Plant," Journal of Clean Energy Technologies, Vol. 1, No. 1, January 2013.
- [4] Seyed Ebrahim Ghasemi\*, Ali Akbar Ranjbar, Abbas Ramiar, "Three-Dimensional Numerical Analysis of Heat Transfer Characteristics of Solar Parabolic Trough Collector with Two Segmental Rings," Journal of Mathematics and Computer Science, 7 (2013) 89-100.

- [5] A.A. Hachicha, I. Rodriguezl, R. Capdevila, A. Oliva . "Heat Transfer Analysis and Numerical Simulation of a Parabolic Trough Collector," Applied Energy 111 (2013) 581-592.
- [6] Zhirong Liao, Xin Li, Chao Xu, Chun Chang, Zhifeng Wang, "Allowable Flux Density on a Solar Central Receiver," 2013.
- [7] Azharul KARIM<sup>1</sup>, Suvash C. SAHA<sup>1</sup>, Sarah MILLER<sup>2</sup> and Prasad K. D. V. YARLAGADDA<sup>1</sup>, "Three Dimensional Simulation of a Parabolic Trough Concentrator Thermal Collector," 50<sup>th</sup> Annual Conference, Australian Solar Energy Society (Australian Solar Council) Melbourne December 2012.
- [8] Tadahum Ahmed Yassen, "Experimental and Theoretical Study of a Parabolic Trough Solar Collector," 2012.
- [9] Arpakarn Wattana\*, Wattanapong Rakwichian\*\*, Wannee Ekaslip\*\*\*, Ammata Tusnapucki\*\*\*\*, "Velocity and Temperature Distribution of Flowing Water in a Solar Parabolic Trough Receiver," International Journal of Renewable Energy, Vol. 6, No.1, January-June 2011.
- [10] Manjunath M S<sup>1</sup>, K Vasudeva Karanth<sup>2</sup>, N Yagnesh Sharma<sup>3</sup>, Member, IAENG, "Three Dimensional Analysis of Conjugate Heat Transfer for Enhancement of Thermal Performance using Finned Tubes in an Economical Unglazed Solar Flat Plate Collector," Proceeding of the World Congress on Engineering, London, U.K. July 6-8, 2011.
- [11] Cheng, He, Xiao, Tao and Xu, "Three-Dimensional Numerical Study of Heat Transfer Characteristics in the Receiver Tube of Parabolic Trough Collector," International Communications in Heat and Mass Transfer 37(7):pp 782-787, 2010.
- [12] D. R. Waghole, G.V. Parishwad, R.M. Warkhedkar, N.K. Sane and V.S. Kulkarni, "Heat Transfer Analysis of Receiver/Absorber Tube of Parabolic Trough Collector," Proceeding of the 37<sup>th</sup> National and 4<sup>th</sup> International Conference on Fluid Mechanics and Fluid Power, IIT Madras, Chennai, India, December 16-18, 2010.
- [13] Fernandez-Garcia, A., Zarza, E., Valenzuela, L., Perze, M., "Parabolic-Trough Solar Collectors and Their Applications," Renewable and Sustainable Energy Reviews 14, 1695-1721, 2010.
- [14] Y. W. Chiu and J. Y. Jang, "3D Numerical and Experimental Analysis for Thermal-Hydraulic Characteristics of flow inside a Circular Tube with different Tune Inserts," Applied Thermal Engineering , Vol. 42, pp. 250-258, 2009.
- [15] Turgut, O. & Onur, "Three Dimensional Numerical and Experimental Study of Forced Convection Heat Transfer on Solar Collector Surface," International Communications in Heat and Mass Transfer, Vol. 36, pp 274-279, 2009.
- [16] Adrian Begin, "Convection Heat Transfer," 2003.
- [17] Solutia. "Therminol VP-1 and Therminol 59 Heat Transfer Fluid," Technical Bulletin 7239115B, St Louis, 1999.
- [18] The Dow Chemical Company, "Syltherm 800 Heat Transfer Fluid," Ams. USA, 1997.
- [19] Cohen G. and Kearny D, "Improved Parabolic Trough Solar Electric System based on the SEGS Experience," Proceeding of the ASES Annual Conference Solar, 94, 147-150, 1994.
- [20] Incropera, F., De Witt, D." Fundamentals of Heat and Mass Transfer," Third Edition. New York, NY: John Wiley and Sons, 1990.
- [21] Dr. Yaghoubi, M.<sup>1</sup>, Akbari Moosavi, M.<sup>2</sup>, "Three Dimensional Thermal Analysis of an Absorber Tube in a Parabolic Trough Collector".
- [22] Begian. A. "Convection Heat Transfer," Second Edition. New York, NY: John Wiley and Sons.
- [23] W. G. le Roux, "Solar Tracking for a Parabolic Trough Dish used in a Solar Thermal Brayton Cycle".

the field of solar energy, computational fluid dynamics and experimental fluid dynamics. She has published more than 10 papers in the International and National Journals and Conferences.



**M. M. Htay** is Assistance Lecturer, Department of Mechanical Engineering, Mandalay Technological University, Mandalay, Myanmar. She has both teaching and research experience more than 8 years in the field of Industrial field. She has published more than 10 papers in the International and National Journals and Conferences.



**M. M. Mon** is a student presently pursuing Ph.D in Mandalay Technological University, Mandalay, Myanmar. Her field of research includes solar energy, heat transfer, computational fluid dynamics and computational heat transfer. She has published more than three papers in International and National Conferences.



**M. M. Soe** is Associate Professor, Department of Mechanical Engineering, Mandalay Technological University, Mandalay, Myanmar. She has both teaching and research experience of more than 20 five years in