

Wind loads on 'Y' plan shape tall building

Ravinder Ahlawat and Ashok K. Ahuja

Abstract— An experimental study was carried out on the models of 'Y' plan shape tall building in an open circuit wind tunnel to investigate the wind loads generated on the building in isolated as well as interference condition. The base shear (F_x), overturning moment (M_y) and torsional moment (M_z) acting on the instrumented model were measured. For the isolated condition, the measurements were made for many wind incidence angles. For studying the interference effects, two similar building models were placed in side-by-side configuration and tandem configuration and the spacing between these models were varied. It is observed that the wind incidence angle greatly affects the wind induced loads on the 'Y' plan shaped building. Depending on the position of the interfering building, the interference effects may either be beneficial or may have an adverse effect.

Index Terms— base shear, overturning moment, tall buildings, torsional moment, Y-shape.

I. INTRODUCTION

Tall buildings have generally been designed with square or rectangular plan shapes. However, recently there has been a growing trend by the architects to design tall buildings with unconventional shapes. Improvement in aesthetic features of a building, restrictions of construction sites and building regulations are some of the reasons that have immensely contributed to the surge in design of buildings with unconventional shapes.

For designing the buildings for wind induced loads, the designers refer to the relevant standards on wind loads (AS/NZS: 1170.2-2002 [1], ASCE: 7-02-2002 [2], BS: 63699-1995 [3], EN: 1991-1-4-2005 [4], IS: 875 (Part-3) 1987 [5]) to obtain the design pressure coefficients and force coefficients. However, these standards provide information for simple cross-sectional shapes with very few wind incidence angles. Information on wind loadings of buildings with unconventional shapes is not available in these codes. Hence, wind tunnel testing is generally carried out on the models of such buildings. Similarly, very little guidance is available for considering the interference effects.

Kwok [6] investigated the effect of building shape on the wind induced response of tall building with rectangular cross section. Kawai [7] investigated the effects of corner cut, recession and roundness on aeroelastic instabilities such as vortex induced excitation and galloping oscillation by wind tunnel tests for square and rectangular prisms. Gomes *et al.* [8] tested the models of irregular-plan shape (L and U shape) in closed circuit wind tunnel to measure the surface pressure distributions. Amin [9] conducted wind tunnel tests

of rectangular buildings having same plan area and height but different side ratios over an extended range of wind incidence angles. The author also analyzed L and T-plan shape buildings comprising of two blocks located in close proximity in a variety of geometric configurations. Gu [10] investigated the effect of different cross-sectional shapes of tall buildings on the wind pressures and wind induced forces. Wind tunnel tests were carried out on 27 typical tall building models. Lam *et al.* [11] measured the dynamic wind loads on a number of H-shaped tall buildings. The authors studied the size effect of the recessed cavities on the wind loading behavior of the building. Bhatnagar [12] studied the effects of various corner modifications on wind loads on buildings. The author also measured the base shear and moments of rectangular-plan buildings with varying length-to-width ratios and L-shaped building with different block sizes. Tanaka *et al.* [13] determined aerodynamic forces and wind pressures acting on square-plan tall building models with various configurations like corner cut, setbacks, helical and so on. Mukherjee *et al.* [14] studied the wind generated pressure developed on different faces of a 'Y' plan shape building.

Although 'Y' plan is quite common, experimental data for such a shape is quite rare and limited, with no information being available for interference effects due to two similar 'Y' plan shaped buildings. Hence, experimental study has been carried out on the model of a 'Y' plan shape building to measure the wind induced loads for isolated as well as interference condition.

II. PROCEDURE FOR PAPER SUBMISSION

A. Wind flow characteristics

In this study, all the tests are conducted in boundary layer wind tunnel having a cross section of 2 m (width) x 2 m (height) and the length of test section as 15 m. Test models are placed on five component load cell at a distance of 10.5 m from the upstream end of test section. Using vortex generators, barrier wall and cubical blocks (Fig. 1), mean wind velocity profile corresponding to terrain category II as per Indian standard on wind load is generated. The experiment is carried out at free stream wind velocity of 10 m/s.

B. Model description

The instrumented and the interfering models used in the study are made of plywood at a geometric scale of 1:200. The dimensions of the 'Y' plan shaped model is shown in Fig. 2. The instrumented and the interfering model are of the same dimensions. The height of each model is 500 mm which represents a prototype of height 100 m. The width

Ravinder Ahlawat, B.Tech. (Civil) 2009, currently M.Tech. Student in the Dept. of Civil Engg., IIT Roorkee;

Ashok K. Ahuja, B.E. (Civil) 1976, M.E. (1979), Ph.D. (1990), Professor of Civil Engg at IIT Roorkee.



Fig. 1. Flow roughening devices placed inside the wind tunnel.

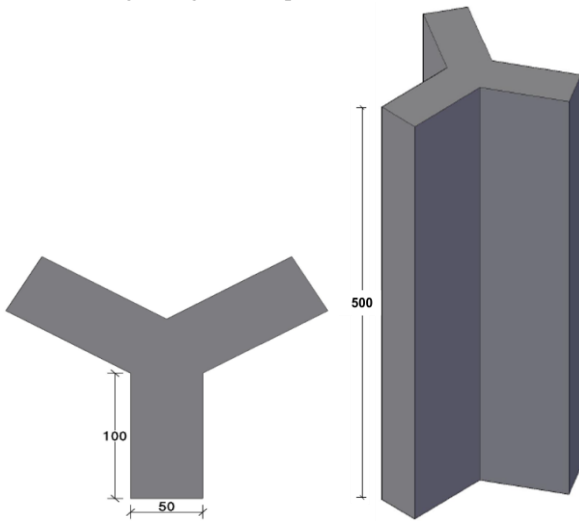

Fig. 2. Dimensions of the model (in mm).

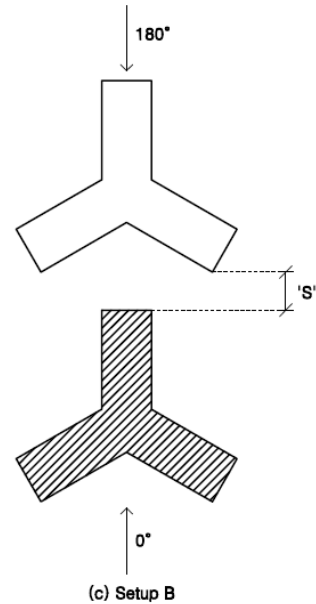
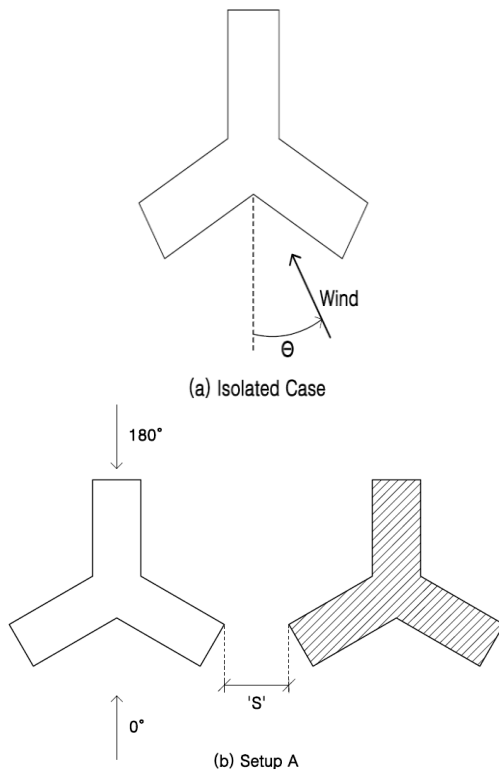

Fig. 3. Isolated and interference configurations.

of the smaller face and the larger face is 50 mm and 100 mm respectively which represent 10 m and 20 m on the prototype.

The model was tested for the following isolated and interference conditions (Fig. 3).

Isolated case: Variation of F_x , M_y and M_z on single instrumented model with varying wind incidence angles (Fig. 3a) 0° to 240° .

Interference case:

Setup A (side-by-side configuration): Variation of F_x , M_y and M_z on instrumented model with spacing of interfering model for wind incidence angles of 0° and 180° (Fig. 3b).

Setup B (tandem configuration): Variation of F_x , M_y and M_z on instrumented model with spacing of interfering model for wind incidence angles of 0° and 180° (Fig. 3c).

C. Measurement technique

As Instrumented model of 'Y' plan shape building is placed on five component load cell. The model is first placed in isolated condition (Fig. 4a). Later, the interfering model is placed in side-by-side configuration (Fig. 4b) and tandem configuration (Fig. 4c). The base shear (F_x), overturning moment (M_y) and torsional moment (M_z) acting on the instrumented model is recorded. For the isolated case, the wind incidence angle is varied from 0° to 240° at an interval of 15° . For interference cases, the measurements are made for wind incidence angles of 0° and 180° . The spacing between the instrumented and the interfering building is also varied. For setup A, the spacing was varied from 0 to 200 mm and for setup B, the spacing was varied from 0 to 600 mm.

III. RESULTS AND DISCUSSION

Variation of base shear (F_x), overturning moment (M_y) and torsional moment (M_z) measured on single instrumented model as a function of wind incidence angle is shown in Figs. 5 to 7. It is noticed from Fig. 5 that the maximum value of F_x is obtained at angles 15° , 105° , 135° and 225° due to entrapment of air and also due to maximum exposed area. Minimum values are obtained at angles of 60° and 180°

because the air entrapment does not occur at these angles. Variation of M_y is identical to that of F_x (Fig. 6). Maximum value of torsional moment (M_z) is obtained at 75° and 195° and minimum value at 45° and 165° . At angles 0° , 60° , 120° , 180° and 240° , M_z is found to be zero. This happens due to the wind flow being parallel to the axis of symmetry of the 'Y' shape.

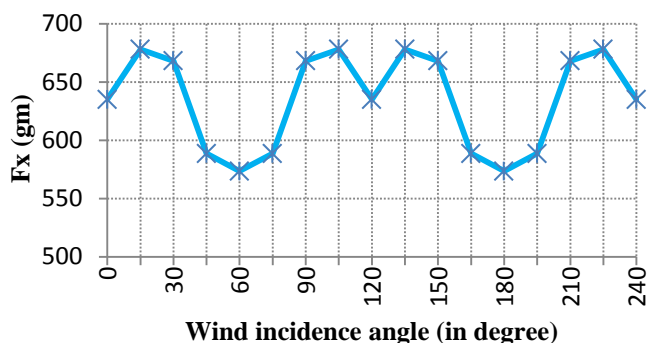

Fig. 5. Variation of base shear (F_x) with wind incidence angle (Isolated case).

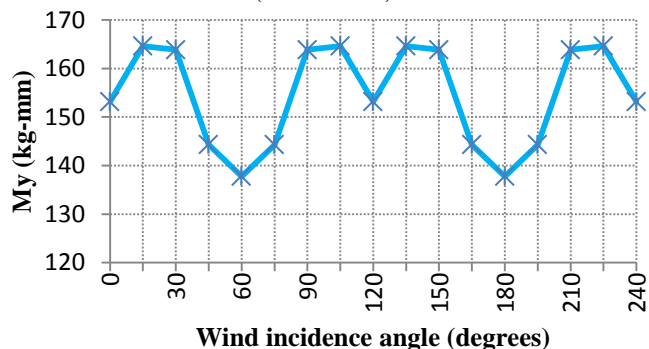

Fig. 6. Variation of overturning moment (M_y) with wind incidence angle (Isolated case).

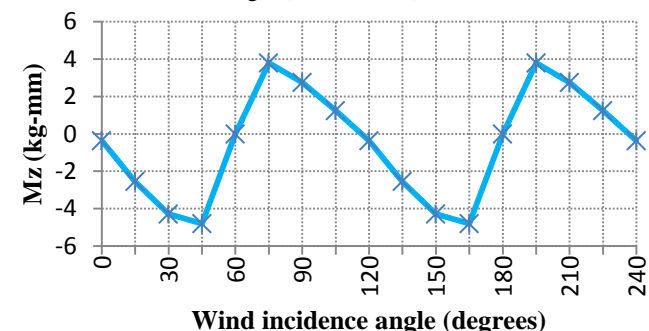

Fig. 7. Variation of torsional moment (M_z) with wind incidence angle (Isolated case).

Figs. 8, 9 and 10 depict the variation of F_x , M_y and M_z with spacing between the instrumented model and the interfering model for interference cases (setup A and B) for 0° and 180° wind incidence angles. For setup A (0°), the base shear increases by 22% for 0 mm spacing as compared to the isolated case. This occurs due to the presence of interfering model on one side which inhibits free flow of wind streams causing additional wind forces to be induced on the instrumented model. Effect of interference reduces as the spacing is increased to 200 mm. However, in case of setup B (0° and 180°), the presence of interfering model on the upstream side causes shielding effect on the instrumented

model resulting in reduced values of F_x as compared to the isolated case. For spacings between 0 and 200 mm, the instrumented model lies in the wake zone of the interfering model. This results in negative values of F_x i.e. wind induced force acts in the upstream direction. Overturning moment (M_y) shows the same trend as that of F_x (Fig. 9).

For setup A, the presence of the interfering building model causes asymmetric wind loading on the instrumented model due to which the torsional moment is generated. Torsional moment decreases rapidly with increase in spacing between the instrumented and the interfering model for setup A with 0° wind incidence angle (Fig. 10). However, for setup A with 180° wind angle, one of the legs of the interfering model diverts the wind on to the instrumented model causing the torsional moment to increase. This phenomenon is observed when the spacing is increased from 0 to 75 mm. As the spacing is increased beyond 75 mm, the torsional values reduce gradually. For setup B, due to the symmetry of 'Y' plan shape, there is symmetric distribution

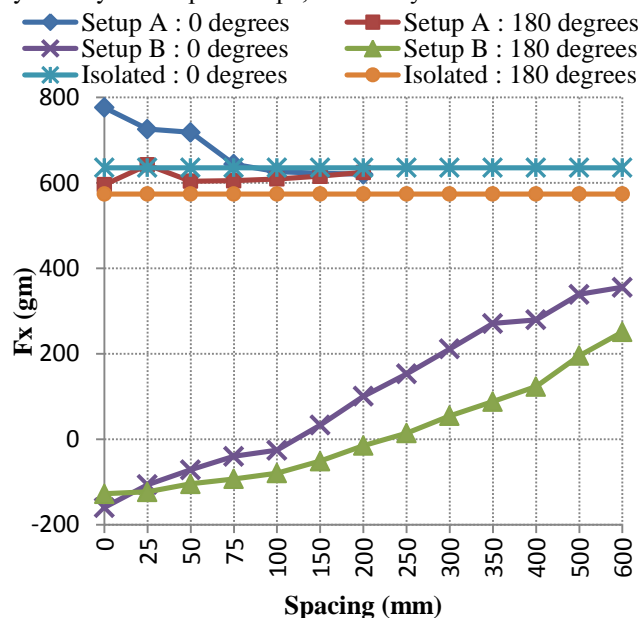

Fig. 8. Variation of base shear (F_x) with spacing.

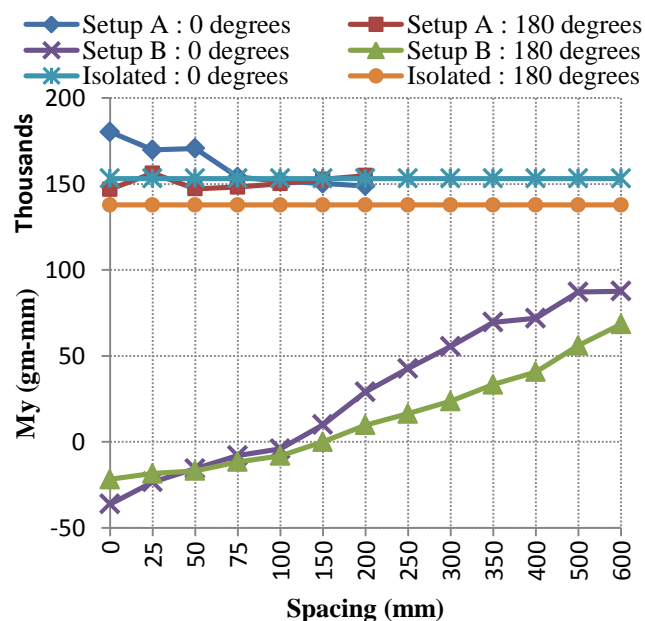

Fig. 9. Variation of overturning moment (M_y) with spacing.

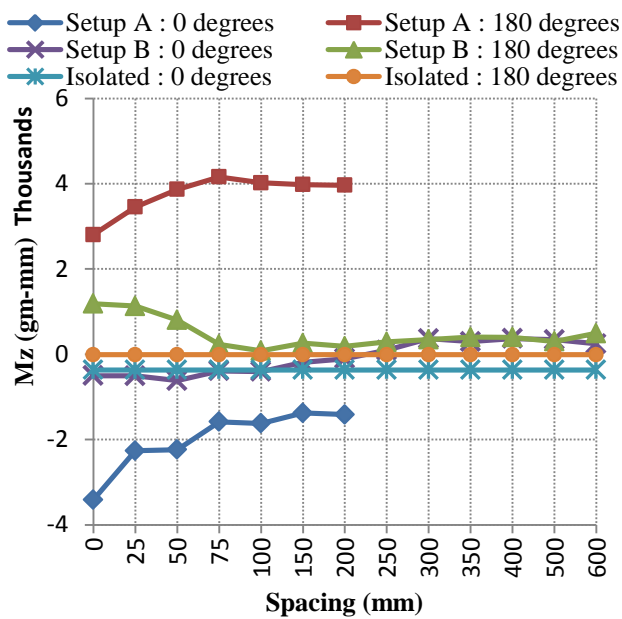

Fig. 10. Variation of torsional moment (Mz) with spacing of wind around the instrumented building. Hence, there is negligible change in torsional moment in setup B as compared to that of isolated case.

IV. CONCLUSIONS

The following conclusions are drawn from the study:-

1. Wind loads on 'Y' plan shape building is highly influenced by the wind incidence angle.
2. Interference effects are beneficial for setup B (tandem configuration) but have an adverse effect in setup A (side-by-side configuration).
3. Torsional moment on the building under interference condition may be greater than that of isolated condition due to the asymmetric distribution of wind around the building.

ACKNOWLEDGMENT

The work presented in this paper is part of the research work being done by the first author for his M.Tech. degree under the supervision of second author.

REFERENCES

[1] AS/NZS: 1170.2. 2002. Structural design actions, Part-2: Wind action.
 [2] ASCE: 7-02. 2002. Minimum design loads for buildings and other structures.
 [3] BS: 63699. 1995. Loading for buildings: Part 2-code of practice for wind loads.
 [4] EN: 1991-1-4. 2005. Euro code 1: Actions on structures wind actions.
 [5] IS:875-Part-3. 1987. Code of practice for design loads (other than earthquake loads) for buildings and structures. BIS, New Delhi.
 [6] Kwok, K.C.S. 1988. Effect of building shape on wind-induced response of tall building. *Journal of Wind Engineering and Industrial Aerodynamics*, 28(1), 381-390.
 [7] Kawai, H. 1998. Effect of corner modifications on aeroelastic instabilities of tall buildings. *Journal of Wind Engineering and Industrial Aerodynamics*, 74, 719-729.

[8] Gomes, M.G., Rodrigues, A.M. and Mendes, P. 2005. Experimental and numerical study of wind pressures on irregular-plan shapes. *J. Wind Engg. Indus. Aerodynam.* 93: 741-756.
 [9] Amin J.A. 2008. Effects of plan shape on wind induced response of tall buildings. Ph. D Thesis, Dept. of Civil Engg., IITR Roorkee, Roorkee, India.
 [10] Gu, M. 2009. Study on wind loads and responses of tall buildings and structures. *Wind Engineering*.
 [11] Lam, K. M., Wong, S. Y., & To, A. P. 2009. Dynamic wind loading of H-shaped tall buildings. In *The Seventh Asia-pacific conference on wind Engineering, Taipei, Taiwan*.
 [12] Bhatnagar, N.K. 2011. Effects of geometrical shapes on wind loads on buildings. Ph.D. Thesis, IIT Roorkee, Roorkee, India.
 [13] Mukherjee, S., Chakraborty, S., Dalui, S. K., & Ahuja, A. K. 2014. Wind induced pressure on 'Y' plan shape tall building. *Wind and Structures*, 19(5), 523-540.
 [14] Tanaka, H., Tamura, Y., Ohtake, K., Nakai, M., & Kim, Y. C. 2012. Experimental investigation of aerodynamic forces and wind pressures acting on tall buildings with various unconventional configurations. *Journal of Wind Engineering and Industrial Aerodynamics*, 107, 179-191.



Ravinder Ahlawat, B.Tech. (Civil) 2009, currently M.Tech. Student in the Dept. of Civil Engg., IIT Roorkee;



Ashok K. Ahuja, B.E. (Civil) 1976, M.E. (1979), Ph.D. (1990), Professor of Civil Engg at IIT Roorkee