

A Comprehensive Review of Dynamic Voltage Restorer

Juned Shaikh, Prabodhkumar Khamparia

Abstract— Power quality is a major concern at the present time. Become important, especially with the introduction of advanced performance devices that are extremely sensitive to the quality of food. Power quality problem is the event that takes place before a non-standard voltage, current, or frequency, leading to end-use hardware failure. One of the main issues addressed here is sagging power. To resolve this issue, one must use custom power devices. One of these devices is the Dynamic Voltage Restorer (DVR), a modern custom power device used in the most efficient power distribution networks. Call has a lower cost, smaller size, rapid dynamic response and disorder. This paper examines a review of the DVR technology and the various applications that have been proposed in the literature.

Index Terms— DVR, Voltage Dips, Swells, Interruption, Power Quality, VSC.

I. INTRODUCTION

Power quality is becoming an increasingly important topic in the performance of many industrial applications such as information technology, significant influence on high technology devices related to communication, advanced control, automation, precise manufacturing technique and on-line service. Users need constant sine wave shape, constant frequency and symmetrical voltage with a constant root mean square (rms) value to continue the production. To satisfy these demands, the disturbances must be eliminated from the system. The typical power quality disturbances are voltage sags, voltage swells, interruptions, phase shifts, harmonics and transients [1][2]. Among the disturbances voltage sag is considered the most severe since the sensitive loads are very susceptible to temporary changes in the voltage. Voltage sag is a short-duration reduction in voltage magnitude. The voltage temporarily drops to a lower value and comes back again after approximately 150ms. Despite their short duration, such events can cause serious problems for a wide range of equipment [1][3]. The characterization of voltage sags is related with:

1. The magnitude of remaining voltage during sag
2. Duration of sag

In practice the magnitude of the remaining voltage has more influence than the duration of sags on the system. Voltage sags are generally within 40% of the nominal voltage in industry. Voltage sags can cost millions of dollars in damaged product, lost production, restarting expenses and danger of breakdown [2][3]. Short circuit faults, motor starting and transformer energizing will cause short duration increase in current and this will cause voltage sags on the line. For certain

Juned Shaikh, PG Student Electrical Engineering Dep't.,SSSITS, Sehore,

Prabodhkumar Khamparia, Assoc. Professor Electrical Engineering Dep't.,SSSITS, Sehore

end users of sensitive equipment the voltage correction device may be the only cost-effective option available.

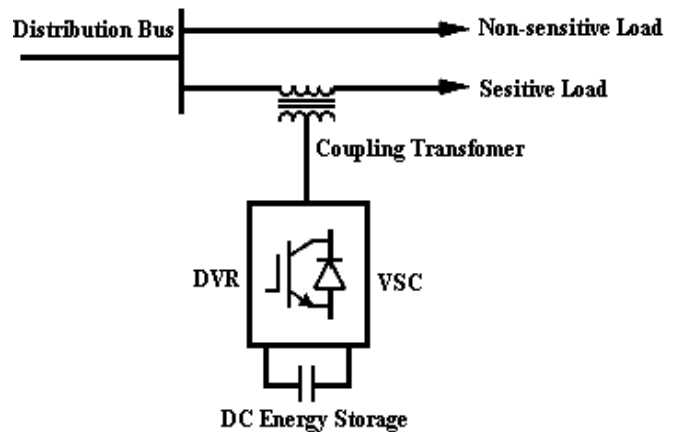

Figure.1: Basic Configuration of DVR

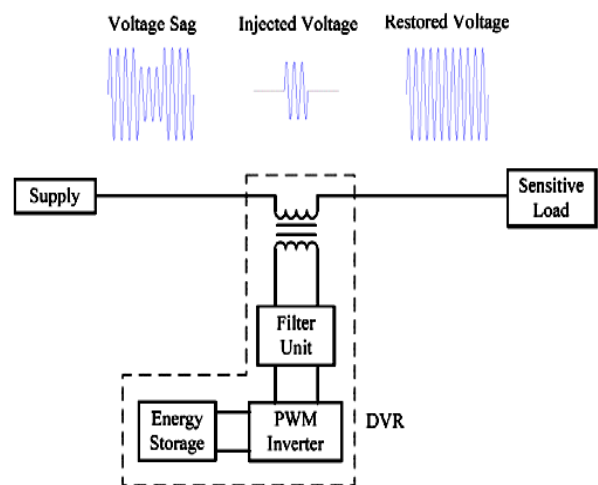

Figure.2: Typical application of DVR in distribution system

Different approaches exist to limit the costs caused by voltage dips and one interesting approach considered here is to use voltage source converters connected in series between the supply system and the sensitive load, this type of devices are often termed a Dynamic Voltage Restorer (DVR).

Unlike uninterruptible power supply (UPS), the DVR is specifically designed for large loads ranging from a few MVA up to 50 MVA or higher [8]. The DVR is fast, flexible and efficient solution to voltage sag problems. It can restore the load voltage within a few milliseconds and hence avoiding any power disruption to that load. The main idea of the DVR is detecting the voltage sag and injecting the missing voltage

in series to the bus by using an injection transformer as shown in Figure 2.

The DVR can be divided into four component blocks, namely:

1. Voltage source PWM inverter
2. Injection/coupling transformer
3. Energy storage device
4. Filter unit.

II. PROPERTIOUS CHOICE OF DVR

There are numerous reasons why DVR is preferred over other devices:

1. Although, SVC predominates the DVR but the latter is still preferred because the SVC has no ability to control active power flow.
2. DVR is less expensive compared to the UPS.
3. UPS also needs high level of maintenance because it has problem of battery leak and have to be replace as often as five years.
4. DVR has a relatively higher energy capacity and costs less compared to SMES device.
5. DVR is smaller in size and costs less compared to DSTATCOM
6. DVR is power efficient device compared to the UPS.

III. CONVENTIONAL CONTROL STRATEGIES

Several control techniques have been proposed for voltage sag compensation such as pre-sag method, in-phase method and minimal energy control [2] [3].

1. General Compensation Technique

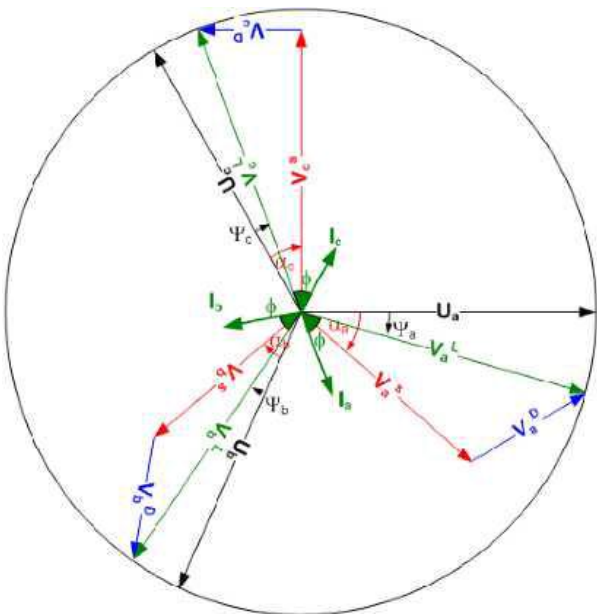

The phasors of load voltages, and also load currents, will rotate with respect to the pre-sag voltages while the phasors of the supply sag voltages will not change. During the normal operation as there is no sag, DVR will not supply any voltage to the load. It will be in a standby mode or it operates in the self charging mode if the energy storage device is fully charged. The energy storage device can be charged either from the power supply itself or from a different source

2. Pre-Sag Compensation Technique

The main defect of this technique is it requires a higher capacity energy storage device. Fig.2 shows the phasor diagram for the pre-sag control strategy in this diagram; $V_{pre-sag}$ and V_{sag} are voltage at the point of common coupling (PCC), respectively before and during the sag. In this case VDVR is the voltage injected by the DVR, which can be obtained as [9]:

$$V_{pre-sag}=V_L, V_{sag}=V_s \quad VDVR=V_{inj} \\ |V_{inj}| = |V_{pre-sag}| - |V_{sag}| \dots\dots (1)$$

$$\theta_{inj} = \tan^{-1} \left\{ \frac{V_{pre-sag} \sin(\theta_{pre-sag})}{V_{pre-sag} \cos(\theta_{pre-sag}) - V_{sag} \cos(\theta_{sag})} \right\}$$

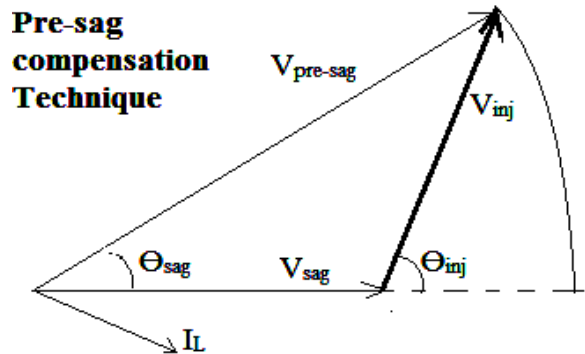

2. In-Phase Compensation Technique

In this technique, only the voltage magnitude is compensated. VDVR is in-phase with the left hand side voltage of DVR. This method minimizes the voltage injected by the DVR, unlike in the pre-sag compensation. Fig.2 shows phase diagram for the in-phase compensation technique [9].

$$VDVR=V_{inj} \\ |V_{inj}| = |V_{pre-sag}| - |V_{sag}|$$

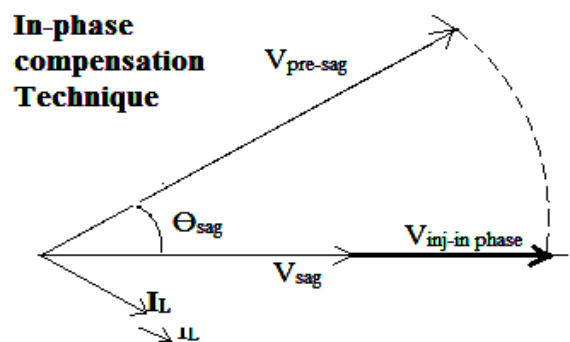

3. Energy Optimized compensation Technique

Pre-sag compensation and in-phase compensation must inject active power to loads almost all the time. Due to the limit of energy storage capacity of DC link, the DVR restoration time and performance are confined in these methods. The fundamental idea of energy optimization method is to make injection active power zero. In order to minimize the use of real power the voltages are injected at 90° phase angle to the supply current. Fig.2 shows a phasor diagram to describe the Energy optimization Control method.

The selection of one of these strategies influences the design of the parameters of DVR. In this paper, the control strategy adopted is Pre-sag compensation to maintain load voltage to pre fault value [9].

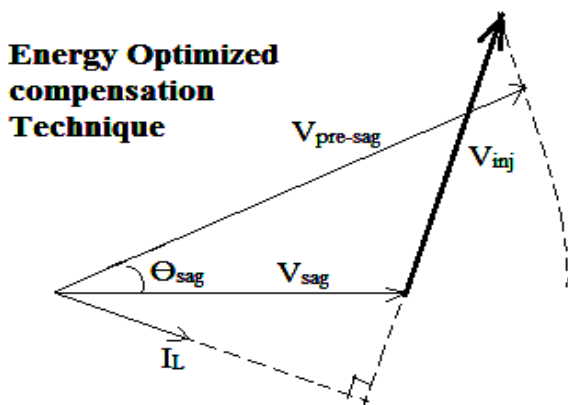

Figure.3: Conventional Control Strategies if DVR [9]

IV. MATHEMATICAL MODEL

During the standby mode (non-faulted times) DVR will do nothing and it should be ensured that the load is not disturbed by the DVR. If the voltage drop caused by the injection transformer exceeds the limit, DVR may inject small voltage to compensate fault. In standby mode, DVR only produces conduction losses because no voltage source PWM inverter switching takes place.

In the event of a fault on the load side of the DVR, a fast rising current surge through the low voltage side of the injection transformer and the voltage source PWM inverter occurs. The protection system guarantees that power semiconductor switching can take place when current levels exceed the switching capability of the power semiconductor. In the event that a critical current level is detected the DVR is bypassed. The bypass system protects DVR components from abnormally high downstream load or fault currents. The DVR should have clever bypass schemes so as not to create additional disturbances onto the system, which will affect the load.

When voltage sag depth to be corrected is between the ratings of DVR, DVR starts to generate the equivalent missing voltage and inject it to the line. DVR will continue the injection process until the bus voltage reaches its pre-fault value. DVR will inject three single-phase ac voltages with controllable amplitude and phase. The voltage sags resulting from faults can be corrected either in the transmission or distribution system. DVR can compensate small disturbances by injecting reactive power and compensate larger disturbances by injecting real power to the system.

To obtain missing voltage DVR compares the distorted source voltage with its pre-fault value and then generate the control signal for PWM. The control unit gives information on required voltage to be inserted and its duration during sag. Sinusoidal pulse width modulation technique is used to control DVR. Solid-state power electronic switching devices are used in PWM [10]. The output of PWM may contain harmonics and they can be filtered on the inverter side or the line side to smooth the voltage waveform. The filtering

scheme should keep the total harmonic distortion (THD) of the remaining voltage at the supply side and the injected voltage within limits determined by standards.

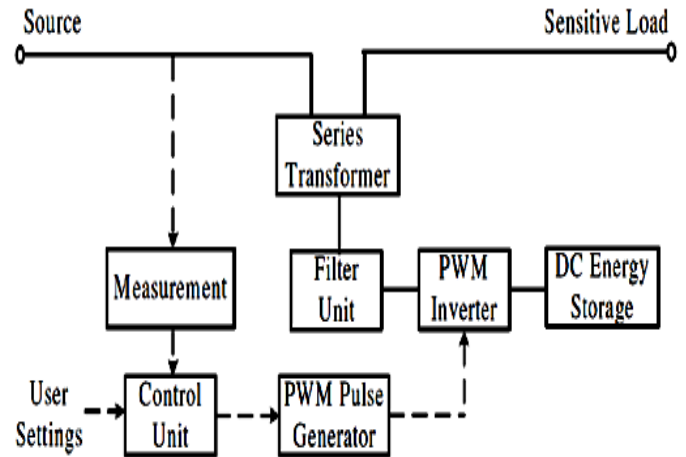

Figure.4: Simplified DVR block

Voltage restoration of DVR needs to inject energy from DVR to distribution system. The required energy for injection during sag may be supplied from the grid or energy storage devices such as batteries or super conducting magnetic energy storage systems. However, the capability of energy storage that usually consists of capacitors in DVR is limited. Therefore, it must be considered how the injection energy can be minimized during deep voltage sags and the load voltage can be made close to pre-fault voltage. This strategy is known as dynamic voltage restorer with minimum energy injection [5][7][10].

The DVR is a series connected device onto the system and it acts as an additional energy source. Carefully design considerations must be taken to integrate the device into the system. Figure.4 can mainly summarize the main operation principle of DVR.

V. CONCLUSION

This paper aims at summarizing the DVR technology and also discusses about the various ins and outs of the implementation procedures for DVR. In section 1 the basic review of the DVR technology was presented, in section 2 the advantage of DVR over other technologies was discussed, in section three various implementation schemes for DVR were discussed and finally in section 3 a mathematical model for future implementation has been covered. It has been shown that there are several ways in which the DVR can be implemented to reduce harmonics in a complex power system.

REFERENCES

- [1] W. E. Brumsickle, R. S. Schneider, G. A. Luckjiff, D. M. Divan, and M. F. McGranaghan, "Dynamic sag correctors: Cost-effective industrial power line conditioning," *IEEE Trans. Ind. Appl.*, vol. 37, no. 1, pp. 212– 217, Jan./Feb. 2001 International Journal of Innovation, Management and Technology, Vol. 1, No. 3, August 2010 ISSN: 2010-0248\
- [2] Ali O Al-Mathunani, Azah Mohamed, and Mohd Alauddin Mohd Ali, "Photovoltaic Based Dynamic Voltage Restorer for Voltage Sag Mitigation" IEEE 2007

- [3] D. Mahinda Vilathgamuwa, H. M. Wijekoon, and S.S. Choi, "Interline Dynamic Voltage Restorer: A Novel and Economical Approach for Multiline Power Quality Compensation" IEEE, 2004
- [4] G. Yaleinkaya, M.H.J. Bollen, P.A. Crossley, "Characterization of voltage sags in industrial distribution systems", IEEE transactions on industry applications, vol.34, no. 4, July/August, pp. 682-688, 1999.
- [5] Haque, M.H., "Compensation of distribution system voltage sag by DVR and D-STATCOM", Power Tech Proceedings, 2001 IEEE Porto, vol.1, pp.10-13, Sept. 2001.
- [6] H. Ezoji, A. Sheikholeslami, M. Tabasi, M.M. Saeednia, "Simulation of Dynamic Voltage Restorer Using Hysteresis Voltage Control", European Journal of Scientific Research, ISSN 1450-216X Vol.27 No.1 (2009), pp.152-166
- [7] Anaya-Lara O, Acha E., "Modeling and analysis of custom power systems by PSCAD/EMTDC", IEEE Transactions on Power Delivery, Vol.17, Issue: 1, Jan. 2002, Pages:266 – 272
- [8] Bollen, M.H.J., "Voltage sags in three-phase systems" Power Engineering Review, IEEE, Vol. 21, Issue: 9, Sept. 2001, pp: 8 - 11, 15.
- [9] M.Madrigal, E.Acha., "Modelling of Custom Power Equipment Using Harmonic Domain Techniques", IEEE 2000.
- [10]] Young-Hoon Cho and Seung-Ki Sul, "Controller Design for Dynamic Voltage Restorer with Harmonics Compensation Function", Industry Applications Conference 2004, 39th Annual meeting, Vol. 3, pp. 1452-1457.

BIOGRAPHY:

Juned Shabbir Shaikh, Student,(M.Tech- Electrical Power System, Department of Electrical & Electronics Engineering, Sri Stya Sai Institute of Science and Technology Sehore.

Prabodhkumar Khamparia, Assoc . Prof, Department of Electrical & Electronics Engineering, Sri Stya Sai Institute of Science and Technology Sehore